

Detrans®

CRANES & COMPONENTS

jakość i nowoczesność tradycją od 1945 roku

Detrans®
d.CBKM
rok założenia 1945

BKM
BYTOM

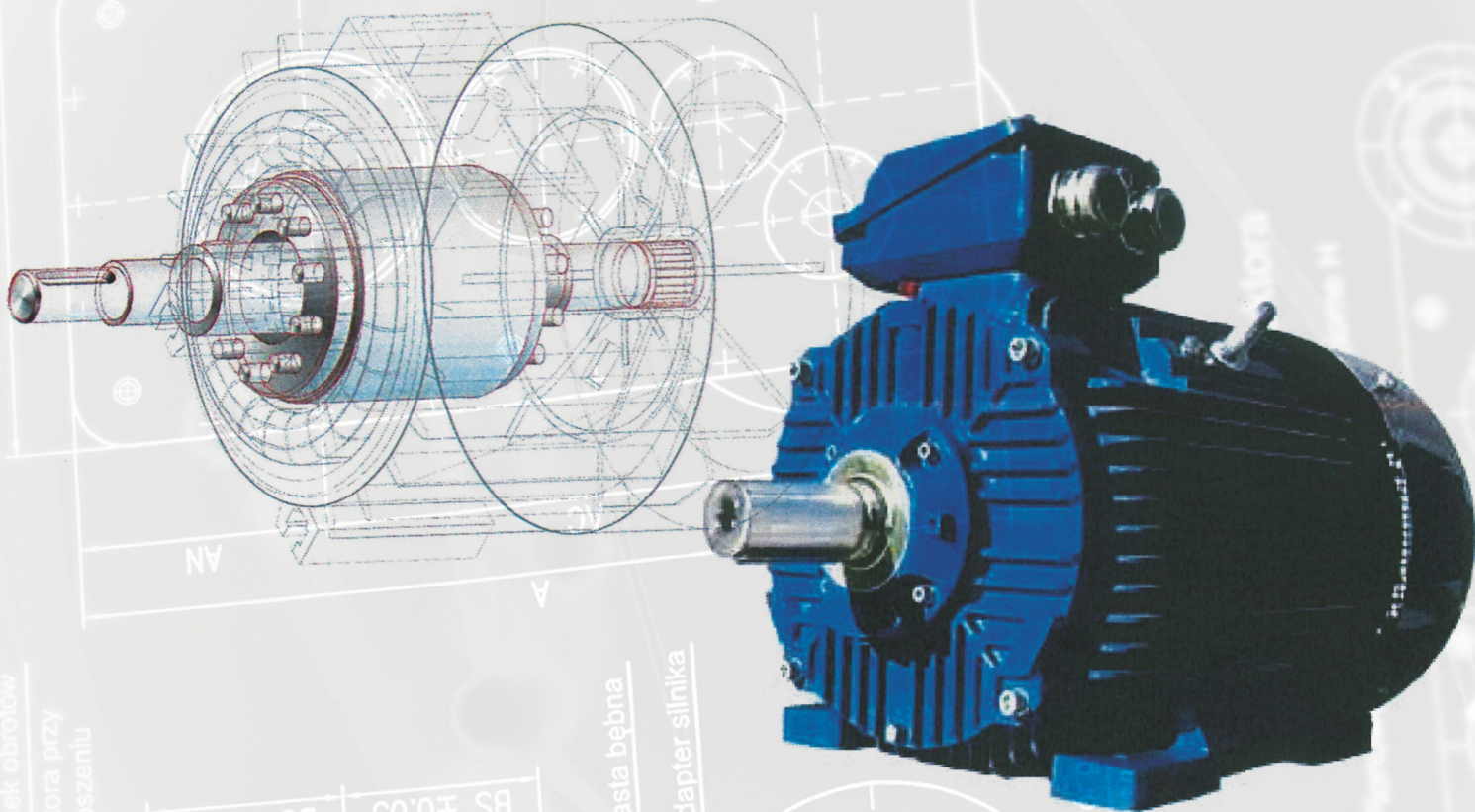

TRÓJFAZOWE SILNIKI INDUKCYJNE Z WIRNIKIEM KLATKOWYM O WYSOKIEJ SPRAWNOŚCI W KLASIE IE3 WIELKOŚCI MECHAN ICZNEJ 90÷315

PREMIUM EFFICIENCY IE3 THREE-PHASE INDUCTION MOTORS WITH
SQUIRREL-CAGE ROTOR SIZE 90÷315

WWW.DETRANS.PL

Spis treści

1. ZASTOSOWANIE	2
<i>Application</i>	
2. CHARAKTERYSTYKA WYKONANIA.....	2
<i>Features</i>	
3. SILNIKI SPEŁNIAJĄ WYMAGANIA NORM.....	2
<i>Motors meet requirements of standards</i>	
4. WYKONANIE NA ŻYCZENIE.....	2
<i>Features on request</i>	
5. SPOSÓB ZAMAWIANIA.....	3
<i>How to order</i>	
6. PARAMETRY EKSPLOATACYJNE SILNIKÓW.....	4
<i>PERFORMANCES OF MOTORS</i>	
7. PARAMETRY EKSPLOATACYJNE SILNIKÓW O ZWIĘKSZONEJ MOCY.....	6
<i>PERFORMANCES OF MOTORS WITH INCREASED OUTPUT POWER</i>	
8. FORMY WYKONANIA MASZYN ELEKTRYCZNYCH WIRUJĄCYCH ZGODNE SĄ Z PN-EN-60034-7.....	8
<i>MOUNTING ARRANGEMENTS ACCORDING TO STANDARD IEC 60034-7</i>	
9. DOPUSZCZALNE OBCIĄŻENIA KOŃCA WAŁU.....	9
<i>PERMISSIBLE SHAFT END LOAD</i>	
10. KADŁUB, TARCZE ŁOŻYSKOWE, ŁAPY.....	12
<i>HAUSING, SHIELDS, FEET</i>	
11. TYP ŁOŻYSK ZASTOSOWANYCH W SILNIKACH.....	12
<i>TYPE OF BEARINGS USED IN MOTORS</i>	
12. WYMIARY SILNIKÓW NA ŁAPACH B3	13
<i>DIMENSIONS FOR FOOT-MOUNTED MOTORS B3</i>	
13. WYMIARY SILNIKÓW KOŁNIERZOWYCH B5.....	14
<i>DIMENSIONS FOR FLANGE-MOUNTED MOTORS B5</i>	
14. WYMIARY SILNIKÓW KOŁNIERZOWYCH NA ŁAPACH B35.....	15
<i>DIMENSIONS FOR FOOT-FLANGE-MOUNTED MOTORS B35</i>	
15. WYMIARY SILNIKÓW Z TARCZĄ KOŁNIERZOWĄ B14.....	17
<i>DIMENSIONS FOR MOTORS WITH FLANGE B14</i>	
16. WIELKOŚĆ MECHANICZNA: 200÷315.....	18
<i>FRAME SIZE: 200÷315</i>	
17. WIELKOŚĆ MECHANICZNA: 90÷180.....	20
<i>FRAME SIZE: 90÷180</i>	

1. ZASTOSOWANIE

Application

- przeznaczenie ogólne,
- miejsce pracy: wewnątrz i na zewnątrz pomieszczeń,
- otoczenie: bez zagrożenia wybuchem, bez mgły solnej i substancji agresywnych wywołujących korozję.
- *general purpose,*
- *operation place: indoors and outdoors,*
- *environment: without explosive conditions, without salt mist, without aggressive corrosive substances.*

2. CHARAKTERYSTYKA WYKONANIA

Features

- moce znamionowe podane są dla pracy S1,
- napięcie znamionowe 230△/400YV lub 400△/690YV,
- częstotliwość napięcia zasilania 50 (Hz),
- temperatura otoczenia do +40(OC),
- wysokość instalowania do 1000 [m] n.p.m.,
- wilgotność względna 95%,
- izolacja klasy F (155°C),
- czujniki PTC uzwojenia: standard dla w.m. 200...315,
- stopień ochrony IP 55,
- kolor malowania RAL 5010,
- z jednym czopem końcowym wału wg rysunku wymiarowego,
- skrzynka zaciskowa z dławnicami i tabliczką 6-zaciskową.
- *rated output for continuous duty S1,*
- *rated voltage 230△/400YV lub 400△/690YV,*
- *frequency 50 [Hz],*
- *environment temperature up to +40(OC),*
- *altitude up to 1000 [m] above sea level,*
- *relative humidity 95%,*
- *insulation class F (155°C),*
- *PTC sensors in winding: standard in size 200...315,*
- *protection degree IP 55,*
- *standard paint color RAL 5010,*
- *one free shaft extension according to dimension drawing,*
- *terminal box with glands and 6 terminals*

3. SILNIKI SPEŁNIAJĄ WYMAGANIA NORM

Motors meet requirements of standards

- IEC 60034-1- Maszyny elektryczne wirujące Część 1-Dane znamionowe i parametry,
- PN-EN-60034-30-1 :2014 - Klasy sprawności silników prądu przemiennego bezpośrednio zasilanych z sieci (kod IE),
- PN-EN-60034-2-1 :2014 - Znormalizowane metody wyznaczania strat i sprawności na podstawie badań.
- *IEC 60034-1- Rotating electrical machines - Part 1: Rating and performance,*
- *IEC 60034-30-1 :2014 - Efficiency classes of line operated AC motors (IE Code),*
- *IEC 60034-2-1:2014 - Standard methods for determining losses and efficiency from test.*

4. WYKONANIA NA ŻYCZENIA

Features on request

- z termistorowymi czujnikami PTC dla w.m. 90...180 lub bimetalowymi wyłącznikami temperatury zabudowanymi w uzwojeniu,
- z czujnikami temperatury łożysk,
- izolacja klasy H,
- stopień ochrony max. IP66,
- podgrzewacze uzwojenia,
- przystosowane do pracy w klimacie tropikalnym TH, TA lub MT,
- z hamulcem elektromagnetycznym,
- z obcym chłodzeniem,
- z enkoderem,
- ze specjalnym końcem wału,
- *with PTC temperature sensors in size 90...180 or with bimetallic thermal switches in the winding ends,*
- *with temperature sensors in bearing shields,*
- *insulation class H,*
- *protection degree max. IP66,*
- *winding heaters,*
- *fit for work in tropical climate TH, TA or MT,*
- *electromagnetic brake,*
- *external cooling,*
- *encored,*
- *special shaft extension,*
- *two cylindrical shaft extension according to dimension drawing,*
- *factory produces various types of motors but constructional details and delivery time are to be individual agreed.*

- z dwoma walcowymi czopami wału wg rysunku wymiarowego,
- fabryka wykonuje również silniki różniące się od wykonania podstawowego po uprzednim uzgodnieniu szczegółów konstrukcyjnych i terminów dostaw.

5. SPOSÓB ZAMAWIANIA

How to order

W zamówieniu należy podać pełne określenie typu silnika, moc, prędkość obrotową, napięcie zasilające, układ połączeń, częstotliwość formę wykonania oraz inne szczegóły niekatalogowego lub specjalnego wykonania,

Wszystkie silniki posiadają znak CE.

In the order there must be clearly given: full designation of the motor, rated output, rated speed, rated voltage, phase connection, frequency, mounting form and all other details for non catalogue execution.

All motors are provided with CE mark.

6. PARAMETRY EKSPLOATACYJNE SILNIKÓW

PERFORMANCES OF MOTORS

Typ silnika Type of motor	Moc znamionowa P _N Rated output P _N		Parametry przy obciążeniu znamionowym Data of rated load								Krotność (przy włączeniu bezpośrednim) Ratio of (at direct switching on)			Momentu bezwładności wirnika J _w Moment of inertia of rotor J _w	Masa IM B3 Weight IM B3	Poziom mocy akustycznej przy 50Hz L _{WA} Noise power level at 50Hz L _{WA}	Poziom ciśnienia akustycznego przy 50Hz L _{PA} Noise pressure level at 50Hz L _{PA}	
			Prędkość n _n Speed n _n	Sprawność(%) η _n /IE3* Efficiency(%) η _n /IE3*			Moment M _n Torque T _n	Współczynnik mocy cos φ _n Power factor cos φ _n	Prąd znamionowy [A] I _n Rated current [A] I _n			Prądu rozruchowego do znamionowego I _s /I _n Starting current to rated current I _s /I _n	Momentu rozruchowego do znamionowego M _s /M _n Starting torque to rated torque T _s /T _n					Momentu maksymalnego do znamionowego M _{max} /M _n Break-down torque to rated torque T _B /T _n
				[min ⁻¹]	50%	75%			100%	[Nm]	[-]							
Silniki 2-biegunowe, prędkość synchroniczna 3000 min ⁻¹ przy 50Hz / 2-pole motors, synchronous speed 3000 min ⁻¹ at 50Hz																		
3Dx90S2	1,5	2,0	2925	82,7	84,4	84,2	4,9	0,85	5,3	3,2	3,0	7,3	2,4	3,5	0,0014	16,5	75	63
3Dx90L2	2,2	3,0	2910	85,4	86,5	85,9	7,2	0,86	7,5	4,5	4,3	8,0	2,7	4,0	0,0019	18,5	75	63
3Dx100L2	3,0	4,0	2915	86,9	87,7	87,1	9,8	0,85	10,2	6,2	5,8	8,5	3,1	4,1	0,0039	25	74	62
3Dx112M2	4,0	5,5	2925	88,7	89,0	88,1	13,0	0,89	12,8	7,8	7,4	8,4	2,3	3,2	0,0075	35,5	74	61
3Dx132S2A	5,5	7,5	2940	87,7	89,2	89,2	17,9	0,89	17,4	10,5	10,0	8,2	2,6	3,4	0,014	55	80	68
3Dx132S2B	7,5	10,0	2940	89,0	90,3	90,1	24,4	0,90	23,2	14,1	13,3	8,5	2,8	3,8	0,017	64	80	68
3Dx160M2A	11,0	15,0	2945	90,3	91,4	91,2	35,7	0,90	33,6	20,4	19,3	7,9	2,1	3,2	0,048	123	82	69
3Dx160M2B	15,0	20,0	2945	89,8	91,9	91,9	48,6	0,90	45,5	27,6	26,2	8,0	2,4	3,3	0,059	132	82	69
3Dx160L2	18,5	25,0	2940	92,2	92,8	92,4	60,1	0,90	55,8	33,8	32,1	7,7	2,3	3,0	0,072	139	82	69
3Dx180M2	22,0	30,0	2955	91,1	92,4	92,7	71,1	0,90	66,2	40,1	38,1	9,2	3,2	3,7	0,095	190	88	75
3Dx200L2A	30,0	40	2965	93,1	93,7	93,5	97	0,90	89	54	51	7,0	2,4	2,8	0,19	275	88	78
3Dx200L2B	37,0	50	2955	93,5	93,8	93,7	120	0,90	110	67	63	6,3	2,2	2,6	0,20	295	88	78
3Dx225M2	45,0	60	2972	94,2	94,6	94,2	145	0,88	136	82	78	6,7	2,0	2,6	0,26	385	90	80
3Dx250M2	55,0	75	2969	94,5	94,8	94,5	177	0,91	161	97	92	6,9	2,2	2,9	0,42	495	87	77
3Dx280S2	75,0	100	2978	94,2	94,8	94,7	241	0,91	218	132	126	6,7	1,8	2,9	0,76	660	87	77
3Dx280M2	90,0	125	2979	94,5	95,1	95,0	289	0,91	261	158	150	7,3	1,8	3,1	0,95	690	92	82
3Dx315S2	110,0	150	2978	95,4	95,6	95,2	353	0,92	315	191	181	6,9	1,9	2,9	0,98	865	87	77
3Dx315M2A	132,0	175	2977	95,8	95,9	95,6	423	0,92	377	228	217	7,3	2,0	2,7	1,28	970	89	78
3Dx315M2B	160,0	220	2978	95,9	96,1	95,8	513	0,92	456	276	262	8,2	2,2	3,1	1,57	1118	89	78
3Dx315M2C	200,0	270	2980	95,9	96,1	95,8	641	0,93	-	341	324	8,1	2,3	3,1	1,74	1185	96	86
Silniki 4-biegunowe, prędkość synchroniczna 1500 min ⁻¹ przy 50Hz / 4-pole motors, synchronous speed 1500 min ⁻¹ at 50Hz																		
3Dx90S4	1,1	1,5	1450	81,8	84,0	84,1	7,2	0,77	4,3	2,6	2,5	7,2	2,3	3,5	0,0036	18	66	54
3Dx90L4	1,5	2,0	1450	83,9	85,5	85,3	9,9	0,78	5,7	3,4	3,3	7,4	2,5	3,4	0,0040	21	66	54
3Dx100L4A	2,2	3,0	1465	85,0	86,8	86,7	14,3	0,80	8,0	4,8	4,6	7,5	2,3	2,9	0,0076	27,5	67	55
3Dx100L4B	3,0	4,0	1465	85,8	87,7	87,7	19,6	0,79	10,9	6,6	6,3	7,4	2,5	3,5	0,0086	31	67	55
3Dx112M4	4,0	5,5	1455	88,5	89,0	88,6	26,3	0,80	14,2	8,6	8,1	7,0	2,1	3,0	0,0115	41,5	70	58
3Dx132S4	5,5	7,5	1465	89,5	90,0	89,6	35,7	0,85	18,1	11,0	10,4	8,5	2,5	3,4	0,036	63	72	59
3Dx132M4	7,5	10,0	1465	89,7	90,6	90,4	49,1	0,83	25,1	15,2	14,4	8,8	2,9	3,8	0,042	67	72	59
3Dx160M4	11,0	15,0	1470	90,9	91,7	91,4	71,5	0,83	36,4	22,0	20,9	7,3	2,6	2,8	0,088	136	74	61
3Dx160L4	15,0	20,0	1475	92,0	92,5	92,1	97,11	0,83	49,3	29,8	28,3	8,1	2,7	3,2	0,104	154	74	61
3Dx180M4	18,5	25,0	1475	91,4	92,5	92,6	20,2	0,85	59,0	35,7	33,9	8,3	2,9	3,0	0,162	190	75	62
3Dx180L4	22,0	30,0	1475	91,4	92,8	93,0	142,4	0,83	71,5	43,3	41,1	8,5	3,2	3,4	0,185	200	76	63
3Dx200L4	30,0	40	1477	94,2	94,3	93,8	194	0,89	90	55	52	6,4	2,1	2,6	0,38	329	80	70
3Dx225S4	37,0	50	1485	94,1	94,4	94,0	238	0,87	114	69	65	6,9	2,0	2,8	0,51	373	73	63

Typ silnika Type of motor	Parametry przy obciążeniu znamionowym Data of rated load											Krotność (przy włączeniu bezpośrednim) Ratio of (at direct switching on)			Momentu bezwładności wirnika J_w Moment of inertia of rotor J_r	Masa IM B3 Weight IM B3	Poziom mocy akustycznej przy 50Hz L_{wa} Noise power level at 50Hz L_{wa}	Poziom ciśnienia akustycznego przy 50Hz L_{pa} Noise pressure level at 50Hz L_{pa}	
	Moc znamionowa P_N Rated output P_N		Prędkość n_n Speed n_n			Sprawność (%) η_n , IEC* Efficiency (%) η_n , IEC*		Moment M_n Torque T_n	Współczynnik mocy $\cos \phi_n$ Power factor $\cos \phi_n$	Prąd znamionowy [A] I_n Rated current [A] I_n			Prądu rozruchowego do znamionowego I_r/I_n Starting current to rated current I_r/I_n	Momentu rozruchowego do znamionowego M_r/M_n Starting torque to rated torque T_r/T_n					Momentu maksymalnego do znamionowego M_{j2}/M_n Break-down torque to rated torque T_{j2}/T_n
	[kW]	[HP]	[min ⁻¹]	50%	75%	100%	[Nm]	[-]	230V△	380V**	400V**	[-]	[-]	[-]					[kgm ²]
Silniki 4-biegunowe, prędkość synchroniczna 1500 min ⁻¹ przy 50Hz / 4-pole motors, synchronous speed 1500 min ⁻¹ at 50Hz																			
SIE225M4	45,0	60	1483	94,4	94,8	94,3	290	0,88	136	82	78	7,1	2,1	2,7	0,59	410	73	63	
3Dx250M4	55,0	75	1487	94,0	94,8	94,7	353	0,90	162	98	93	7,6	2,5	2,9	1,00	520	85	75	
3Dx280S4	75,0	100	1488	93,9	95,0	95,0	481	0,91	218	132	125	6,8	2,0	2,5	1,37	710	87	77	
3Dx280M4	90,0	125	1491	94,9	95,5	95,4	576	0,89	266	161	153	8,4	2,6	3,0	1,80	761	87	77	
3Dx315S4	110,0	150	1488	95,1	95,5	95,4	706	0,90	322	195	185	6,6	2,0	2,4	2,25	920	85	75	
3Dx315M4A	132,0	175	1489	95,6	95,9	95,6	847	0,91	381	231	219	7,9	2,3	2,8	2,59	1030	86	76	
3Dx315M4B	160,0	220	1490	95,9	96,1	95,8	1026	0,90	466	282	268	8,5	2,4	3,1	2,80	1130	87	77	
3Dx315M4C	200,0	270	1488	95,8	96,2	96,2	1284	0,90	-	351	333	8,1	2,4	2,9	3,46	1205	92	82	
Silniki 6-biegunowe, prędkość synchroniczna 1000 min ⁻¹ przy 50Hz / 6-pole motors, synchronous speed 1000 min ⁻¹ at 50Hz																			
3Dx90S6	0,75	1,0	940	77,2	79,3	78,9	7,6	0,70	3,4	2,1	2,0	4,3	1,7	2,4	0,0032	16	62	50	
3Dx90L6	1,1	1,5	940	79,9	81,9	81,0	11,1	0,70	4,9	2,9	2,8	4,5	2,1	2,6	0,0090	19	62	50	
3Dx100L6	1,5	2,0	960	81,1	82,8	82,5	14,9	0,74	6,2	3,7	3,5	6,2	2,6	3,3	0,0100	23,5	64	52	
3Dx112M6	2,2	3,0	965	83,9	84,9	84,3	21,8	0,76	8,6	5,2	5,0	5,9	2,1	2,6	0,0177	34	65	53	
3Dx132S6	3,0	4,0	965	86,8	87,8	87,0	29,7	0,81	10,7	6,5	6,2	6,6	2,2	2,9	0,0440	54	67	55	
3Dx132M6A	4,0	5,5	965	89,1	89,2	88,0	39,8	0,81	14,1	8,5	8,1	6,6	2,3	3,0	0,0579	62	70	58	
3Dx132M6B	5,5	7,5	960	88,9	89,1	88,0	54,7	0,81	19,4	11,7	11,1	6,7	2,4	3,1	0,0637	66	73	61	
3Dx160M6	7,5	10,0	970	89,0	89,9	89,5	73,8	0,82	25,7	15,5	14,8	6,8	2,1	2,9	0,102	134	74	61	
3Dx160L6	11,0	15,0	970	91,0	91,0	90,3	108,3	0,82	37,3	22,6	21,4	7,0	2,2	3,0	0,123	146	74	61	
3Dx180L6	15,0	20,0	980	90,0	91,3	91,2	146,2	0,81	51,0	30,9	29,3	7,3	3,3	2,8	0,276	198	74	61	
3Dx200L6A	18,5	25	988	91,3	92,0	91,7	179	0,81	63	38	36	5,8	2,0	2,4	0,50	285	74	64	
3Dx200L6B	22,0	30	987	91,7	92,2	92,2	213	0,82	73	44	42	5,7	2,0	2,1	0,64	309	74	64	
3Dx225M6	30,0	40	989	92,3	92,9	92,9	290	0,83	98	59	56	6,4	1,9	2,3	0,89	392	74	64	
3Dx250M6	37,0	50	991	92,2	93,4	93,3	357	0,82	121	73	70	6,7	2,0	2,6	1,23	440	76	66	
3Dx280S6	45,0	60	993	92,9	93,8	93,7	433	0,81	149	90	86	7,3	2,3	2,6	1,70	635	76	66	
3Dx280M6	55,0	75	992	93,8	94,4	94,1	529	0,82	179	108	103	6,8	2,3	2,6	1,90	695	76	66	
3Dx315S6	75,0	100	992	94,6	95,0	94,7	722	0,82	242	147	139	7,1	2,4	2,6	2,40	900	77	67	
3Dx315M6A	90,0	125	993	95,1	95,4	95,1	866	0,82	29	175	167	7,6	2,6	2,7	2,93	965	79	69	
3Dx315M6B	110,0	150	992	95,2	95,6	95,2	1059	0,82	354	214	203	7,5	2,8	2,8	3,46	1110	79	69	
3Dx315M6C	132,0	175	992	95,4	95,8	95,4	1271	0,83	-	253	241	7,0	2,5	2,5	4,21	1230	80	70	
3Dx315M6D	160,0	220	992	95,2	95,7	95,6	1540	0,78	-	326	310	8,0	3,3	2,7	4,36	1235	80	70	

* sprawność wyznaczona wg PN-EN 60034-2-1:2014 Pkt. 6.1.3 Metoda 2-1-1B- start poszczególnych, straty dodatkowe wg metody start resztkowych

**230V Δ /:./400VY - standardowe silniki wielkości mech. 90÷100

400V Δ /:./690VY - standardowe silniki wielkości mech. 112÷315

Producent zastrzega sobie prawo zmian parametrów zawartych w katalogu wynikających z ciągłego doskonalenia produktów bez wcześniejszego informowania.

*efficiency is determinate acc. to IEC 60034-2-1:2014 Clause 6.1.3 Method 2-1-1B - summation of losses, additional losses acc. to the method of residual loss.

**230V Δ /:./400VY - standard motors size 90÷100

400V Δ /:./690VY - standard motors size 112÷315

As part of our development program, we reserve the rights to alert or amend any of the specifications without giving prior notice.

7. PARAMETRY EKSPLOATACYJNE SILNIKÓW O ZWIĘKSZONEJ MOCY

PERFORMANCES OF MOTORS WITH INCREASED OUTPUT POWER

Typ silnika Type of motor	Moc znamionowa P_n Rated output P_n		Parametry przy obciążeniu znamionowym Data of rated load						Krotność (przy włączeniu bezpośrednim) Ratio of (at direct switching on)			Moment bezwładności wirnika J_n Moment of inertia of rotor J_n	Masa IM B3 Weight IM B3	Poziom mocy akustycznej przy 50Hz L_{pa} Noise power level at 50Hz L_{pa}	Poziom ciśnienia akustycznego przy 50Hz L_{pa} Noise pressure level at 50Hz L_{pa}			
			Prędkość n_n Speed n_n	Sprawność (%) η_n , IEC* Efficiency (%) η_n , IEC*			Moment M_n Torque T_n	Współczynnik mocy $\cos \phi_n$ Power factor $\cos \phi_n$	Prąd znamionowy [A] I_n Rated current [A] I_n	Prądu rozruchowego do znamionowego I_s/I_n Starting current to rated current I_s/I_n	Momentu rozruchowego do znamionowego M_s/M_n Starting torque to rated torque T_s/T_n					Momentu maksymalnego do znamionowego M_b/M_n Break-down torque to rated torque T_b/T_n		
				[min ⁻¹]	50%	75%											100%	[Nm]
Silniki 2-biegunowe, prędkość synchroniczna 3000 min ⁻¹ przy 50Hz / 6-pole motors, synchronous speed 3000 min ⁻¹ at 50Hz																		
3Dx90L2A	3,0	4,0	2920	86,7	87,7	87,1	9,81	0,85	10,2	6,2	5,8	9,0	2,6	3,9	0,0019	20,5	75	63
3Dx100L2A	4,0	5,5	2920	88,1	88,8	88,1	13,1	0,85	13,4	8,1	7,7	9,0	3,2	4,1	0,0039	30	74	62
3Dx112M2A	5,5	7,5	2925	88,9	89,8	89,2	17,9	0,87	17,8	10,8	10,2	7,4	2,0	3,2	0,0075	39,5	74	61
3Dx112M2B	7,5	10,0	2930	90,9	91,1	90,1	24,4	0,87	24,0	14,5	13,8	8,4	2,5	3,5	0,0075	49	74	61
3Dx132M2	9,2	12,3	2935	90,5	91,2	90,7	29,9	0,88	28,9	17,5	16,6	9,7	3,2	3,8	0,020	73	80	68
3Dx132M2A	11,0	15,0	2925	92,1	91,9	91,2	35,9	0,89	34,1	20,6	19,6	8,1	2,6	3,8	0,021	76	80	68
3Dx160L2A	22,0	30,0	2950	91,9	92,8	92,7	71,2	0,89	66,9	40,5	38,5	9,7	3,2	3,8	0,072	148	82	69
3Dx200L2C	45,0	60,0	2962	94,5	94,6	94,0	145	0,90	134	81	77	7,3	2,6	2,5	0,21	301	88	78
3Dx200L2D	55,0	75,0	2950	95,2	95,2	94,3	178	0,90	163	98	94	6,4	2,3	2,6	0,24	322	88	78
3Dx225M2C	55,0	75,0	2970	94,8	95,0	94,5	177	0,89	164	99	94	7,1	2,1	3,1	0,33	425	90	80
3Dx250M2C	75,0	100,0	2969	94,3	94,8	94,7	241	0,88	226	137	130	7,2	2,3	3,2	0,42	498	87	77
3Dx280M2C	110,0	150,0	2978	95,4	95,6	95,2	353	0,92	315	191	181	6,9	1,9	2,9	0,98	748	92	82
3Dx280M2D	132,0	175,0	2977	95,8	95,9	95,6	423	0,92	377	228	217	7,3	2,0	2,7	1,28	864	92	82

Typ silnika Type of motor	Moc znamionowa P_N Rated output P_N		Parametry przy obciążeniu znamionowym Data of rated load							Krotność (przy włączeniu bezpośrednim) Ratio of (at direct switching on)			Momentu bezwładności wirnika J_v Moment of inertia of rotor J_v	Masa IM B3 Weight IM B3	Poziom mocy akustycznej przy 50Hz L_{wa} Noise power level at 50Hz L_{wa}	Poziom ciśnienia akustycznego przy 50Hz L_{pa} Noise pressure level at 50Hz L_{pa}		
			Prędkość n_n Speed n_n	Sprawność (%) η_n , IEC* Efficiency (%) η_n , IEC*			Moment M_n Torque T_n	Współczynnik mocy $\cos \varphi_n$ Power factor $\cos \varphi_n$	Prąd znamionowy [A] I_n Rated current [A] I_n			Prądu rozruchowego do znamionowego I_r/I_n Starting current to rated current I_r/I_n					Momentu rozruchowego do znamionowego M_r/M_n Starting torque to rated torque T_r/T_n	Momentu maksymalnego do znamionowego M_b/M_n Break-down torque to rated torque T_b/T_n
	[kW]	[HP]		[min ⁻¹]	50%	75%			100%	[Nm]	[-]		230V△	380V**	400V**	[-]		
Silniki 4-biegunowe, prędkość synchroniczna 1500 min⁻¹ przy 50Hz / 4-pole motors, synchronous speed 1500 min⁻¹ at 50Hz																		
3Dx90L4A	2,2	3,0	1455	84,8	86,7	86,7	14,4	0,77	8,3	5,0	4,8	8,1	2,9	3,9	0,004	25	66	54
3Dx100L4C	4,0	5,5	1465	85,6	87,7	88,6	26,1	0,79	14,3	8,7	8,2	8,3	3,0	4,1	0,0086	34	67	55
3Dx112M4A	5,5	7,5	1460	89,4	90,2	89,6	36,0	0,80	19,3	11,7	11,1	7,2	2,5	3,3	0,0115	54	70	58
3Dx132M4A	9,2	12,3	1460	91,0	91,5	91,0	60,2	0,83	30,6	18,5	17,6	9,0	3,1	4,1	0,050	93	72	60
3Dx132M4B	11,0	15,0	1460	91,7	92,1	91,4	72,0	0,83	36,4	22,0	20,9	9,5	3,2	4,4	0,057	97	72	60
3Dx160L4A	18,5	25,0	1475	91,8	92,7	92,6	119,8	0,81	61,9	37,5	35,6	8,5	3,0	3,5	0,118	150	74	61
3Dx200L4C	37,0	50,0	1475	93,2	93,5	93,9	240	0,86	115	70	66	6,7	2,3	2,7	0,38	330	80	70
3Dx200L4D	45,0	60,0	1481	93,5	94,1	94,2	290	0,85	141	85	81	7,3	2,6	3,3	0,49	367	80	70
3Dx225M4C	55,0	75,0	1484	93,6	94,6	94,6	354	0,86	170	103	98	7,1	2,1	2,9	0,66	431	73	63
3Dx250M4C	75,0	100,0	1483	94,5	94,9	95,0	483	0,90	220	133	127	6,8	2,3	3,0	1,15	553	85	75
3Dx280M4C	110,0	150,0	1488	95,1	95,5	95,4	706	0,90	322	195	185	6,6	2,0	2,4	2,25	839	87	77
Silniki 6-biegunowe, prędkość synchroniczna 1000 min⁻¹ przy 50Hz / 6-pole motors, synchronous speed 1000 min⁻¹ at 50Hz																		
3Dx90L6A	1,5	2,0	940	81,2	81,7	82,5	15,2	0,70	6,5	3,9	3,7	4,7	2,5	3,0	0,0090	21	62	50
3Dx100L6A	2,2	3,0	960	84,2	84,7	84,3	21,9	0,73	9,0	5,4	5,2	6,5	2,9	3,6	0,0100	26	64	52
3Dx112M6A	3,0	4,0	960	86,0	86,7	85,6	29,7	0,75	11,7	7,1	6,7	5,5	1,5	2,3	0,0177	36	65	53
3Dx132M6C	7,5	10,0	965	88,4	89,5	89,1	74,2	0,76	27,8	16,8	16,0	7,7	3,1	3,8	0,0637	73	73	61
3Dx225M6C	37,0	50,0	991	91,8	92,8	93,3	357	0,77	129	78	74	8,6	2,4	2,6	1,09	432	74	64
3Dx250M6C	45,0	60,0	992	93,2	93,8	93,7	433	0,82	147	89	85	6,9	2,0	2,6	1,55	489	76	66
3Dx280M6C	75,0	100,0	992	94,6	95,0	94,7	722	0,82	242	147	139	7,1	2,4	2,6	2,40	785	77	67

* silnik na etapie budowy prototypu oraz badań

**sprawność wyznaczona wg PN-EN 60034-2-1:2014 Pkt. 6.1.3 Metoda 2-1-1B- start poszczególnych, straty dodatkowe wg metody start resztkowych, efficiency is determinate acc. to IEC 60034-2-1:2014 Clause 6.1.3 Method 2-1-1B - summation of losses, additional losses acc. to the method of residual loss.

***230V △/400V Y - standardowe silniki wielkości mech. 90÷100

400V △/690V Y - standardowe silniki wielkości mech. 112÷315

Producent zastrzega sobie prawo zmian parametrów zawartych w katalogu wynikających z ciągłego doskonalenia produktów bez wcześniejszego informowania.

* efficiency is determinate acc. to IEC 60034-2-1:2014 Clause 6.1.3 Method 2-1-1B - summation of losses, additional losses acc. to the method of residual loss



**230V △/400V Y - standard motors size 90÷100

400V △/690V Y - standard motors size 112÷315

As part of our development program, we reserve the rights to alert or amend any of the specifications without giving prior notice.

8. FORMY WYKONANIA MASZYN ELEKTRYCZNYCH WIRUJĄCYCH ZGODNE SĄ Z PN-EN-60034-7

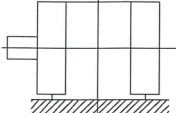
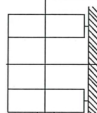
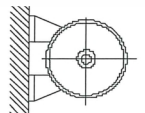
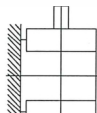
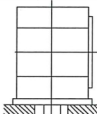
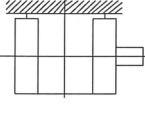
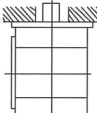
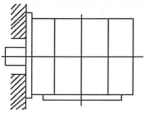
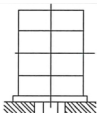
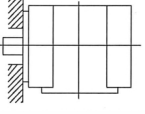
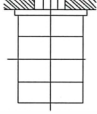
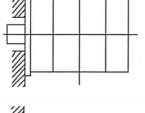
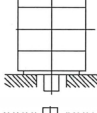
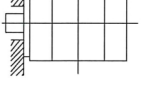
MOUNTING ARRANGEMENTS ACCORDING TO STANDARD IEC 60034-7

	Walek poziomy / Horizontal shaft			Walek pionowy / Vertical shaft	
	Oznaczenie / Designation			Oznaczenie / Designation	
	System II	System I		System II	System I
	IM 1001 Standard	IM 1001 Standard		IM 1011 Option*	IM V5 Option*
	IM 1051 Standard	IM B3 Standard		IM 1031 Option*	IM V6 Option*
	IM 1061 Standard	IM B6 Standard		IM 2011 Option*	IM V15 Option*
	IM 1071 Standard	IM B7 Standard		IM 2031 Option*	IM V36 Option*
	IM 2001 Standard	IM B8 Standard		IM 3011 Option*	IM V1 Option*
	IM 2101 Standard	IM B34 Standard		IM 3031 Option*	IM V3 Option*
	IM 3001 Standard	IM B5 Standard		IM 3611 Option*	IM V18 Option*
	IM 3601 Standard	IM B14 Standard		IM 3631 Option*	IM V19 Option*

* Silniki w wykonaniach IM 1011, IM 2011, IM 3011 oraz IM 3611 mogą mieć daszek ochronny.

* The motors versions IM 1011, IM 2011, IM 3011 and IM 3611 can have a protective cap.

9. DOPUSZCZALNE OBCIĄŻENIA KOŃCA WAŁU

PERMISSIBLE SHAFT END LOAD

Typ silnika Motor type	Maksymalna siła promieniowa [kN] Maximum radial force [kN]		Maksymalna siła osiowa [kN] Maximum axial force [kN]		
	$F_R(x=0)$	$F_R(x=\max)$	F_p	F_{a1}	F_{a2}
3Dx90S2	0,79	0,66	0,64	0,44	0,84
3Dx90L2	0,79	0,66	0,64	0,44	0,84
3Dx90L2A	0,79	0,66	0,64	0,44	0,84
3Dx90S4	1,00	0,83	0,80	0,65	1,05
3Dx90L4	1,00	0,83	0,80	0,65	1,05
3Dx90L4A	1,00	0,83	0,80	0,65	1,05
3Dx90S6	1,15	0,95	0,90	0,77	1,17
3Dx90L6	1,15	0,95	0,90	0,77	1,17
3Dx90L6A	1,15	0,95	0,90	0,77	1,17
3Dx100L2	1,11	0,89	0,90	0,61	1,17
3Dx100L2A	1,11	0,89	0,90	0,61	1,17
3Dx100L4A	1,39	1,12	1,12	0,90	1,46
3Dx100L4B	1,39	1,12	1,12	0,90	1,46
3Dx100L6	1,60	1,29	1,26	1,08	1,64
3Dx100L6A	1,60	1,29	1,26	1,08	1,64
3Dx112M2	1,56	1,22	1,23	0,84	1,60
3Dx112M2A	1,56	1,22	1,23	0,84	1,60
3Dx112M2B	1,56	1,22	1,23	0,84	1,60
3Dx112M4	1,92	1,58	1,50	1,19	1,96
3Dx112M4A	1,92	1,58	1,50	1,19	1,96
3Dx112M6	2,20	1,80	1,69	1,26	2,20
3Dx112M6A	2,20	1,80	1,69	1,26	2,20
3Dx132S2A	2,11	1,65	1,82	0,98	2,37
3Dx132S2B	2,11	1,65	1,82	0,98	2,37
3Dx132S2	2,11	1,65	1,82	0,98	2,37
3Dx132M2	2,11	1,65	1,82	0,98	2,37
3Dx132S4	2,67	2,08	2,31	1,36	3,00
3Dx132M4	2,67	2,08	2,31	1,36	3,00
3Dx132M4A	2,67	2,08	2,31	1,36	3,00
3Dx132M4B	2,67	2,08	2,31	1,36	3,00
3Dx132S6	3,06	2,39	2,51	1,40	3,26

Typ silnika
Motor type

Maksymalna siła promieniowa [kN]
Maximum radial force [kN]

Maksymalna siła osiowa [kN]
Maximum axial force [kN]

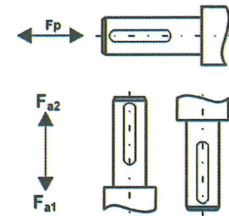
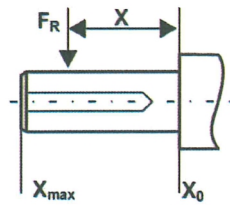

	$F_r(x=0)$	$F_r(x=\max)$	F_p	F_{a1}	F_{a2}
3Dx132M6A	3,06	2,39	2,51	1,40	3,26
3Dx132M6B	3,06	2,39	2,51	1,40	3,26
3Dx132M6C	3,06	2,39	2,51	1,40	3,26
3Dx160M2A	2,43	1,88	1,97	1,00	2,56
3Dx160M2B	2,43	1,88	1,97	1,00	2,56
3Dx160L2	2,43	1,88	1,97	1,00	2,56
3Dx160M4	3,06	2,38	2,54	1,43	3,31
3Dx160L4	3,06	2,38	2,54	1,43	3,31
3Dx160M63	3,54	2,81	2,83	1,80	3,68
SIE160L6	3,54	2,81	2,83	1,80	3,68
3Dx180M2	2,61	2,13	2,20	1,00	2,87
3Dx180M4	3,30	2,68	2,83	1,37	3,68
3Dx180L4	3,30	2,68	2,83	1,37	3,68
3Dx180L6	3,78	3,07	3,17	1,93	4,12
3Dx200L2A	2,91	2,44	2,24	1,72	2,92
3Dx200L2B	2,85	2,39	2,23	1,67	2,93
3Dx200L2C	2,82	2,36	2,22	1,65	2,95
3Dx200L2D	2,69	2,26	2,18	1,57	2,97
3Dx200L4	3,61	3,03	2,81	2,12	3,70
3Dx200L4C	3,61	3,03	2,81	2,12	3,70
3Dx200L4D	3,34	2,80	2,73	1,90	3,80
3Dx200L6A	4,31	3,62	3,62	2,92	4,56
3Dx200L6B	4,06	3,40	3,54	2,71	4,65
3Dx225S4	4,18	3,40	3,19	2,42	4,16
3Dx225M2	3,31	2,81	2,53	1,93	3,29
3Dx225M2C	3,08	2,61	2,46	1,72	3,42
3Dx225M4	3,97	3,23	3,13	2,26	4,24
3Dx225M4C	3,83	3,12	3,09	2,14	4,30
3Dx225M6	4,57	3,72	3,98	2,95	5,33
3Dx225M6C	4,27	3,48	3,89	2,69	5,47
3Dx250M2	4,09	3,39	3,11	2,33	4,13
3Dx250M2C	4,09	3,39	3,11	2,33	4,13
3Dx250M4	4,90	4,06	3,85	2,68	5,36
3Dx250M4C	4,68	3,88	3,79	2,46	5,50
3Dx250M6	5,92	4,90	4,99	3,81	6,55
3Dx250M6C	5,55	4,60	4,87	3,43	6,77

Typ silnika Motor type	Maksymalna siła promieniowa [kN] Maximum radial force [kN]		Maksymalna siła osiowa [kN] Maximum axial force [kN]		
	$F_r(x=0)$	$F_r(x=\max)$	F_p	F_{a1}	F_{a2}
3Dx280S2	3,94	3,34	3,07	2,01	4,43
3Dx280S4	6,69	5,67	5,01	3,65	6,77
3Dx280S6	7,86	6,67	5,79	4,32	7,70
3Dx280M2	3,80	3,22	3,03	1,89	4,49
3Dx280M2C	3,52	2,99	2,95	1,62	4,66
3Dx280M2D	2,94	2,50	2,79	1,02	5,06
3Dx280M4	6,15	5,22	4,86	3,16	7,04
3Dx280M4C	5,65	4,79	4,72	2,58	7,46
3Dx280M6	7,69	6,52	5,75	4,19	7,75
3Dx280M6C	7,10	6,02	5,58	3,52	8,22
3Dx315S2	3,56	3,08	2,96	1,63	4,69
3Dx315S4	5,75	4,82	4,74	2,71	7,37
3Dx315S6	7,21	6,04	5,61	3,84	8,14
3Dx315M2A	3,07	2,65	2,82	1,23	4,89
3Dx315M2B	2,67	2,31	2,71	0,91	5,05
3Dx315M4A	5,40	4,52	4,64	2,41	7,53
3Dx315M4B	5,16	4,33	4,58	2,20	7,64
3Dx315M6A	6,75	5,66	5,48	3,22	8,40
3Dx315M6B	6,27	5,33	5,34	2,68	8,78
3Dx315M2C	2,84	2,48	2,71	0,63	5,37
3Dx315M4C	6,27	5,33	4,34	1,46	8,06
3Dx315M6C	7,57	6,44	5,08	1,87	9,23
3Dx315M6D	7,47	6,36	5,05	1,82	9,22

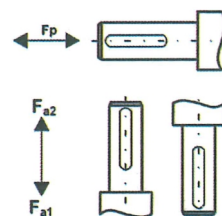
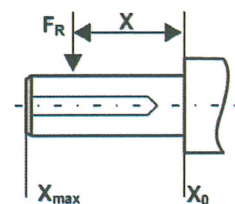

10. KADŁUB, TARCZE ŁOŻYSKOWE, ŁAPY

HAUSING, SHIELDS, FEET

Wielkość silnika Frame size	Tarcza kołnierkowa Flange 85	Kadłub silnika Housing	Tarcze łożyskowe End shields	Łapy Feet
3Dx90	Żeliwo Cast iron	Aluminium	Aluminium	Aluminium – przykręcane screwed
3Dx100	Żeliwo Cast iron	Aluminium	Aluminium	Aluminium – przykręcane screwede
3Dx112	Żeliwo Cast iron	Aluminium	Żeliwo Cast iron	Aluminium – przykręcane screwed
3Dx132	Żeliwo Cast iron	Aluminium	Żeliwo Cast iron	Aluminium – przykręcane screwed
3Dx160	Żeliwo Cast iron	Żeliwo Cast iron	Żeliwo Cast iron	Żeliwo – przykręcane lub przylane Cast iron screwed or integrated
3Dx180	Żeliwo Cast iron	Żeliwo Cast iron	Żeliwo Cast iron	Żeliwo – przykręcane lub przylane Cast iron screwed or integrated
3Dx200	Żeliwo Cast iron	Żeliwo Cast iron	Żeliwo Cast iron	Żeliwo – przykręcane lub przylane Cast iron screwed or integrated
3Dx225	Żeliwo Cast iron	Żeliwo Cast iron	Żeliwo Cast iron	Żeliwo – przykręcane lub przylane Cast iron screwed or integrated
3Dx250	Żeliwo Cast iron	Żeliwo Cast iron	Żeliwo Cast iron	Żeliwo – przykręcane lub przylane Cast iron screwed or integrated
3Dx280	Żeliwo Cast iron	Żeliwo Cast iron	Żeliwo Cast iron	Żeliwo – przykręcane lub przylane Cast iron screwed or integrated
3Dx315	Żeliwo Cast iron	Żeliwo Cast iron	Żeliwo Cast iron	Żeliwo – przykręcane lub przylane Cast iron screwed or integrated
3Dx315M6B,6C,6D	Żeliwo Cast iron	Żeliwo Cast iron	Żeliwo Cast iron	Żeliwo – przykręcane lub przylane Cast iron screwed or integrated

11. TYP ŁOŻYSK ZASTOSOWANYCH W SILNIKACH

TYPE OF BEARINGS USED IN MOTORS

Wielkość silnika Frame size	Liczba biegunów Number of poles	Łożyska Bearings
3Dx90	2 + 6	6205 C3
3Dx100	2 + 6	6206 C3
3Dx112	2 + 6	6306 C3
3Dx132	2 + 6	6308 C3
3Dx160	2 + 6	6309 C3
3Dx180	2 + 6	6311 C3
3Dx200	2 + 6	6312 C3
3Dx225	2 + 6	6313 C3
3Dx250	2 + 6	6315 C3
3Dx280	2	6315 C3
3Dx280	4 + 6	6318 C3
3Dx315S, MA, MB	2	6315 C3
3Dx315MC	2	6316 C3
3Dx315S, MA, MB	4 + 6	6318 C3
3Dx315MC, MD	4 + 6	6320C3/6318C3

12. WYMIARY SILNIKÓW NA ŁAPACH B3

DIMENSIONS FOR FOOT-MOUNTED MOTORS B3

Typ silnika Type of motor	A	B	B1	C	D	E	F	GA	H	HA	K	AA	AB	AC	BB	HD	L
3Dx90S2,4,6	140	100	125	56	24	50	8	27	90	10	10	47	182	200	153	238	331
3Dx90L2	140	100	125	56	24	50	8	27	90	10	10	47	182	200	153	238	331
3Dx90L2A,4,6,	140	100	125	56	24	50	8	27	90	10	12	47	182	200	153	238	356
3Dx90L4A,6A**	140	100	125	56	24	50	8	27	90	10	12	47	182	200	153	238	
3Dx100L2,6	160	140	-	63	28	60	8	31	100	12	12	52	202	215	170	257	377
3SI E100L2A,4A,4B,6A	160	140	-	63	28	60	8	31	100	12	12	52	202	215	170	257	417
3Dx100L4C**	160	140	-	63	28	60	8	31	100	12	12	52	202	215	170	257	
3Dx112M2,6	190	140	-	70	28	60	8	31	112	14	12	52	222	248	170	280	398
3Dx112M2A,4,6A	190	140	-	70	28	60	8	31	112	14	12	52	222	248	170	280	425
3Dx112M2B,4A3	190	140	-	70	28	60	8	31	112	14	12	52	222	248	170	280	485
3IE132S2A,2B,4,6	216	140	178	89	38	80	10	41	132	18	12	61	266	288	220	329	512
3Dx132S2	216	140	178	89	38	80	10	41	132	18	12	61	266	288	220	329	542
3Dx132M4,6A,6B	216	140	178	89	38	80	10	41	132	18	12	61	266	288	220	329	512
3Dx132M2,2A,4A,4B,6C	216	140	178	89	38	80	10	41	132	18	12	61	266	288	220	329	542
3Dx160M2A,2B,4,6	254	210	254	108	42	110	12	45	160	25	15	81	320	340	300	383	643
3Dx160L2,4,6	254	210	254	108	42	110	12	45	160	25	15	81	320	340	300	383	643
3Dx180M2,4	279	241	279	121	48	110	14	51,5	180	27	15	92	353	360	320	414	723
3Dx180L4,6	279	241	279	121	48	110	14	51,5	180	27	15	92	353	360	320	414	723
3Dx200L2A,B,C,D; L4,C,D; L6A,B	318	305	-	133	55	110	16	59	200	32	19	80	400	455	380	520	850
3Dx225S4	356	286	311	149	60	140	18	64	225	34	19	85	440	500	380	570	930
3Dx225M2,C	356	286	311	149	55	110	16	59	225	34	19	85	440	500	380	570	900
3SI E225M4,C; M6,C	356	286	311	149	60	140	18	64	225	34	19	85	440	500	380	570	930
3SI E250M2,C	406	349	-	168	60	140	18	64	250	37	24	90	480	545	445	635	1010
3Dx250M4,C; M6,C	406	349	-	168	65	140	18	69	250	37	24	90	480	545	445	635	1040
3SI E280S2	457	368	419	190	65	140	18	69	280	40	24	105	550	600	520	720	1135
3Dx280S4; S6	457	368	419	190	75	140	20	79,5	280	40	24	105	550	600	520	720	1135
3Dx280M2,C,D	457	368	419	190	65	140	18	69	280	40	24	105	550	600	520	720	1135
3Dx280M4,C; M6,C	457	368	419	190	75	140	20	79,5	280	40	24	105	550	600	520	720	1135
3Dx315S2	508	406	457	216	65	140	18	69	315	48	28	120	610	630	565	805	1235
3Dx315S4; S6	508	406	457	216	80	170	22	85	315	48	28	120	610	630	565	805	1265
3Dx315M2A	508	406	457	216	65	140	18	69	315	48	28	120	610	630	565	805	1235
3Dx315M2B	508	406	457	216	65	140	18	69	315	48	28	120	610	630	565	805	1235
3Dx315M4A; 6A	508	406	457	216	80	170	22	85	315	48	28	120	610	630	565	805	1265
3SI E315M4B	508	406	457	216	80	170	22	85	315	48	28	120	610	630	565	805	1265
3Dx315M6B	508	406	457	216	80	170	22	85	315	48	28	135	610	630	600	805	1355
3SI E315M2C	508	406	457	216	70	140	20	74,5	315	48	28	135	610	630	600	805	1290
3Dx315M4C	508	406	457	216	80	170	22	85	315	48	28	135	610	630	600	805	1320
3Dx315M6C	508	406	457	216	80	170	22	85	315	48	28	135	610	630	600	805	1320
3Dx315M6D	508	406	457	216	90	170	25	95	315	48	28	135	610	630	600	805	1320

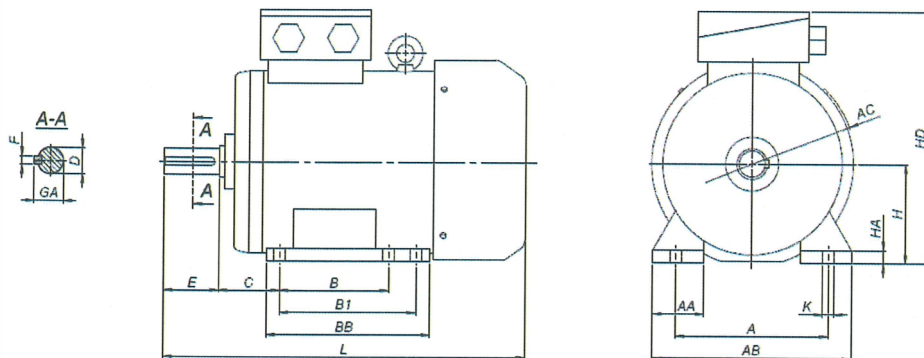

3Dx90-112



3Dx132-315



* silniki w fazie testów

* prototypes made only

Producent zastrzega sobie prawo zmian wymiarów gabarytowych przedstawionych w katalogu.

The manufacturer reserves the right to modify the overall dimensions of the products shown in this catalogue.

13. WYMIARY SILNIKÓW KOŁNIERZOWYCH B5

DIMENSIONS FOR FLANGE-MOUNTED MOTORS B5

Typ silnika Type of motor	D	E	F	GA	AC	HB	L	LA	M	N	P	T	S	
													∅	holes
3DxK90S2,4,6,L2	24	50	8	27	200	148	331	8	165	130	200	3,5	12	4
3DxK90L2A,4,6	24	50	8	27	200	148	356	8	165	130	200	3,5	12	4
3DxK90L4A,6A**	24	50	8	27	200	148		8	165	130	200	3,5	12	4
3DxK100L2,6	28	60	8	31	215	157	377	11	215	180	250	4	15	4
3DxK100L2A,4A,4B,6A	28	60	8	31	215	157	417	11	215	180	250	4	15	4
3DxK100L4C**	28	60	8	31	215	157		11	215	180	250	4	15	4
3DxK112M2,6	28	60	8	31	248	168	398	12	215	180	250	4	15	4
3DxK112M2A,M4,6A	28	60	8	31	248	168	425	12	215	180	250	4	15	4
3DxK112M2B,4A	28	60	8	31	248	168	485	12	215	180	250	4	15	4
3DxK132S2A,2B,4,6	38	80	10	41	288	197	512	12	265	230	300	4	15	4
3DxK132S2	38	80	10	41	288	197	542	12	265	230	300	4	15	4
3DxK132M4,6A,6B	38	80	10	41	288	197	512	12	265	230	300	4	15	4
3DxK132M2,2A,4A,4B,6C	38	80	10	41	288	197	542	12	265	230	300	4	15	4
3DxK160M2A,2B,4,6	42	110	12	45	340	223	643	13	300	250	350	5	19	4
3DxK160L2,4,6	42	110	12	45	340	223	643	13	300	250	350	5	19	4
3DxK180M2,4	48	110	14	51,5	360	234	723	13	300	250	350	5	19	4
3DxK180L4,6	48	110	14	51,5	360	234	723	13	300	250	350	5	19	4
3DxK200L2A,B,C,D; L4,C,D; L6A,B	55	110	16	59	455	320	850	16,5	350	300	400	5	19	4
3DxK225S4	60	140	18	64	500	345	930	18	400	350	450	5	19	8
3DxK225M2,C	55	110	16	59	500	345	900	18	400	350	450	5	19	8
3DxK225M4,C; M6,C	60	140	18	64	500	345	930	18	400	350	450	5	19	8
3DxK250M2,C	60	140	18	64	545	385	1010	23	500	450	550	5	19	8
3DxK250M4,C; M6,C	65	140	18	69	545	385	1040	23	500	450	550	5	19	8
3DxK280S2	65	140	18	69	600	440	1135	23	500	450	550	5	19	8

Typ silnika Type of motor	D	E	F	GA	AC	HB	L	LA	M	N	P	T	S	
													∅	holes
3DxK280S4; S6	75	140	20	79,5	600	440	1135	23	500	450	550	5	19	8
3DxK280M2,C,D	65	140	18	69	600	440	1135	23	500	450	550	5	19	8
3DxK280M4,C; M6,C	75	140	20	79,5	600	440	1135	23	500	450	550	5	19	8
3DxK315S2	65	140	18	69	630	490	1235	23	600	550	660	6	24	8
3Dx315S4; S6	80	170	22	85	630	490	1265	23	600	550	660	6	24	8
3DxK315M2A	65	140	18	69	630	490	1235	23	600	550	660	6	24	8
3DxK315M2B	65	140	18	69	630	490	1235	23	600	550	660	6	24	8
3DxK315M4A; 6A	80	170	22	85	630	490	1265	23	600	550	660	6	24	8
3DxK315M4B	80	170	22	85	630	490	1265	23	600	550	660	6	24	8
3DxK315M6B*	80	170	22	85	630	490	1355	23	600	550	660	6	24	8
3SI EK315M2C*	70	140	20	74,5	630	490	1290	23	600	550	660	6	24	8
3DxK315M4C*	80	170	22	85	630	490	1320	23	600	550	660	6	24	8
3SI EK315M6C*	80	170	22	85	630	490	1320	23	600	550	660	6	24	8
3SI EK315M6D*	90	170	25	95	630	490	1320	23	600	550	660	6	24	8

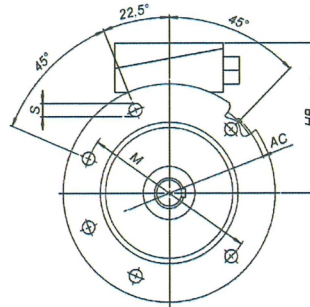
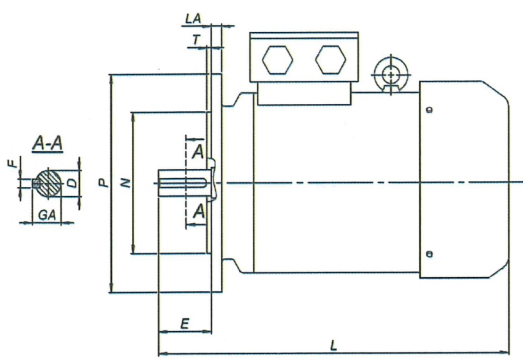

3DxK90-112

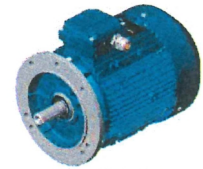

3DxK132-315

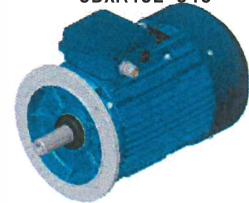

•only in vt

* silniki w fazie testów

* prototypes made only

Producent zastrzega sobie prawo zmian wymiarów gabarytowych przedstawionych w katalogu.

The manufacturer reserves the right to modify the overall dimensions of the products shown in this catalogue.

14. WYMIARY SILNIKÓW KOŁNIERZOWYCH NA ŁAPACH B35 DIMENSIONS FOR FOOT-FLANGE-MOUNTED MOTORS B35

Typ silnika Type of motor	A	B	B1	C	D	E	F	GA	H	HA	K	AA	AB	AC	BB	HD	L	LA	M	N	P	T	S	
																							∅	holes
3DxL90S2,4,6	140	100	125	56	24	50	8	27	90	10	10	47	182	200	153	238	331	8	165	130	200	3,5	12	4
3DxL90L2	140	125	125	56	24	50	8	27	90	10	10	47	182	200	153	238	331	8	165	130	200	3,5	12	4
3DxL90L2A,4,6	140	125	-	56	24	50	8	27	90	10	12	47	182	200	153	238	356	8	165	130	200	3,5	12	4
3DxL90L4A,6A**	140	125	-	56	24	50	8	27	90	10	12	47	182	200	153	238		8	165	130	200	3,5	12	4
3DxL100L2,6	160	140	-	63	28	60	8	31	100	12	12	52	202	215	170	257	377	11	215	180	250	4	15	4
3DxL100L2A,4A,4B,6A	160	140	-	63	28	60	8	31	100	12	12	52	202	215	170	257	417	11	215	180	250	4	15	4
3SI EL100L4A**	160	140	-	63	28	60	8	31	100	12	12	52	202	215	170	257		11	215	180	250	4	15	4

Typ silnika Type of motor	A	B	B1	C	D	E	F	GA	H	HA	K	AA	AB	AC	BB	HD	L	LA	M	N	P	T	S	
																							∅	holes
3SI EL112M2,6	190	140	-	70	28	60	8	31	112	14	12	52	222	248	170	280	398	12	215	180	250	4	15	4
3DxL112M2A,4,6A	190	140	178	70	28	60	8	31	112	14	12	52	222	248	170	280	425	12	215	180	250	4	15	4
3DxL112M2B,4A	190	140	178	70	28	60	8	31	112	14	12	52	222	248	170	280	485	12	215	180	250	4	15	4
3DxL132S2A,2B,4,6	216	140	178	89	38	80	10	41	132	18	12	61	266	288	220	329	512	12	265	230	300	4	15	4
3DxL132S2	216	140	178	89	38	80	10	41	132	18	12	61	266	288	220	329	542	12	265	230	300	4	15	4
3DxL132M4,6A,6B	216	178	178	89	38	80	10	41	132	18	12	61	266	288	220	329	512	12	265	230	300	4	15	4
3DxL132M2,2A,4A,4B,6C	216	178	254	89	38	80	10	41	132	18	12	61	266	288	220	329	542	12	265	230	300	4	15	4
3SI EL160M2A,2B,4,6	254	210	254	108	42	110	12	45	160	25	15	81	320	340	300	383	643	13	300	250	350	5	19	4
3DxL160L2,4,6	254	254	279	108	42	110	12	45	160	25	15	81	320	340	300	383	643	13	300	250	350	5	19	4
3DxL180M2,4	279	241	279	121	48	110	14	51,5	180	27	15	92	353	360	320	414	723	13	300	250	350	5	19	4
3DxL180L4,6	279	279	-	121	48	110	14	51,5	180	27	15	92	353	360	320	414	723	13	300	250	350	5	19	4
3DxL200L2A,B,C,D; L4,C,D; L6A,B	318	305	311	133	55	110	16	59	200	32	19	80	400	455	380	520	850	16,5	350	300	400	5	19	4
3DxL225S4	356	286	311	149	60	140	18	64	225	34	19	85	440	500	380	570	930	18	400	350	450	5	19	8
3DxL225M2,C	356	286	311	149	55	110	16	59	225	34	19	85	440	500	380	570	900	18	400	350	450	5	19	8
3DxL225M4,C; M6,C	356	286	-	149	60	140	18	64	225	34	19	85	440	500	380	570	930	18	400	350	450	5	19	8
3DxL250M2,C	406	349	-	168	60	140	18	64	250	37	24	90	480	545	445	635	1010	23	500	450	550	5	19	8
3SI EL250M4,C; M6,C	406	349	419	168	65	140	18	69	250	37	24	90	480	545	445	635	1040	23	500	450	550	5	19	8
3DxL280S2	457	368	419	190	65	140	18	69	280	40	24	105	550	600	520	720	1135	23	500	450	550	5	19	8
3DxL280S4; S6	457	368	419	190	75	140	20	79,5	280	40	24	105	550	600	520	720	1135	23	500	450	550	5	19	8
3DxL280M2,C,D	457	368	419	190	65	140	18	69	280	40	24	105	550	600	520	720	1135	23	500	450	550	5	19	8
3DxL280M4,C; M6,C	457	368	457	190	75	140	20	79,5	280	40	24	105	550	600	520	720	1135	23	500	450	550	5	19	8
3DxL315S2	508	406	457	216	65	140	18	69	315	48	28	120	610	630	565	805	1235	23	600	550	660	6	24	8
3DxL315S4; S6	508	406	457	216	80	170	22	85	315	48	28	120	610	630	565	805	1265	23	600	550	660	6	24	8
3DxL315M2A	508	406	457	216	65	140	18	69	315	48	28	120	610	630	565	805	1235	23	600	550	660	6	24	8
3DxL315M2B	508	406	457	216	65	140	18	69	315	48	28	135	610	630	565	805	1235	23	600	550	660	6	24	8
3DxL315M4A,6A	508	406	457	216	80	170	22	85	315	48	28	120	610	630	565	805	1265	23	600	550	660	6	24	8
3DxL315M4B	508	406	457	216	80	170	22	85	315	48	28	120	610	630	565	805	1265	23	600	550	660	6	24	8
3DxL315M6B	508	406	457	216	80	170	22	85	315	48	28	135	610	630	600	805	1355	23	600	550	660	6	24	8
3DxL315M2C	508	406	457	216	70	140	20	74,5	315	48	28	135	610	630	600	805	1290	23	600	550	660	6	24	8
3DxL315M4C	508	406	457	216	80	170	22	85	315	48	28	135	610	630	600	805	1320	23	600	550	660	6	24	8
3DxL315M6C	508	406	457	216	80	170	22	85	315	48	28	135	610	630	600	805	1320	23	600	550	660	6	24	8
3DxL315M6D	508	406	457	216	90	170	25	95	315	48	28	135	610	630	600	805	1320	23	600	550	660	6	24	8

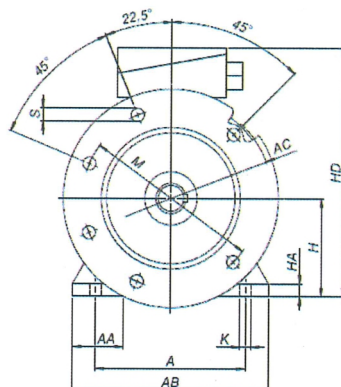
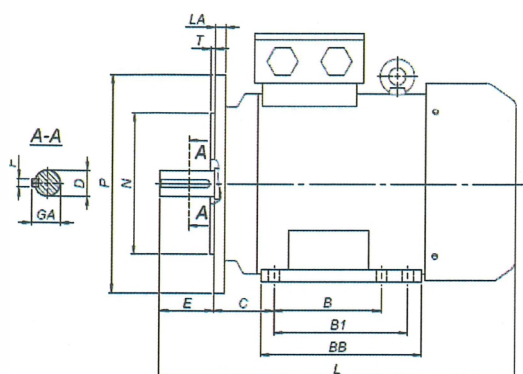

3DxL90-112

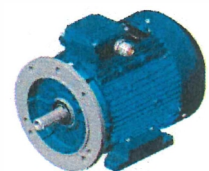

3DxL132-315

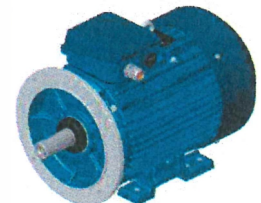

* silniki w fazie testów / prototypes made only

Producent zastrzega sobie prawo zmian wymiarów gabarytowych przedstawionych w katalogu.

The manufacturer reserves the right to modify the overall dimensions of the products shown in this catalogue.

15. WYMIARY SILNIKÓW Z TARCZĄ KOŁNIERZOWĄ B14

DIMENSIONS FOR MOTORS WITH FLANGE B14

Typ silnika Type of motor	D	E	F	GA	AC	HB	L	LA	Kołnierz Flange	M	N	P	T	S	
														∅	holes
3DxK90S2,4,6 ,L2	24	50	8	27	200	148	331	10	FT130/C160	130	110	160	3,5	M8	4
									FT115/C140	115	95	140	3,0	M8	4
3DxK90L2A,4,6	24	50	8	27	200	148	356	10	FT130/C160	130	110	160	3,5	M8	4
									FT115/C140	115	95	140	3,0	M8	4
3DxK90L4A,6A**	24	50	8	27	200	148		10	FT130/C160	130	110	160	3,5	M8	4
									FT115/C140	115	95	140	3,0	M8	4
3DxK100L2,6	28	60	8	31	215	157	377	12	FT165/C200	165	130	200	3,5	M10	4
									FT130/C160	130	110	160	3,5	M8	4
3DxK100L2A,4A,4B ,6A	28	60	8	31	215	157	417	12	FT165/C200	165	130	200	3,5	M10	4
									FT130/C160	130	110	160	3,5	M8	4
3DxK100L4C**	28	60	8	31	215	157		12	FT165/C200	165	130	200	3,5	M10	4
									FT130/C160	130	110	160	3,5	M8	4
3DxK112M2,6	28	60	8	31	248	168	398	12	FT165/C200	165	130	200	3,5	M10	4
									FT130/C160	130	110	160	3,5	M8	4
3DxK112M2A,4,6C	28	60	8	31	248	168	425	12	FT165/C200	165	130	200	3,5	M10	4
									FT130/C160	130	110	160	3,5	M8	4
3DxK112M2B,4A	28	60	8	31	248	168	485	12	FT165/C200	165	130	200	3,5	M10	4
									FT130/C160	130	110	160	3,5	M8	4
3DxK132S2A ,2B,4 ,6	38	80	10	41	288	197	512	12	FT215/C250	215	180	250	4,0	M12	4
									FT165/C200	165	130	200	3,5	M10	4
3DxK132S2	38	80	10	41	288	197	542	12	FT215/C250	215	180	250	4,0	M12	4
									FT165/C200	165	130	200	3,5	M10	4
3DxK132M4 ,6A,6B	38	80	10	41	288	197	512	12	FT215/C250	215	180	250	4,0	M12	4
									FT165/C200	165	130	200	3,5	M10	4
3DxK132M2,2A,4A,4B ,6C	38	80	10	41	288	197	542	12	FT215/C250	215	180	250	4,0	M12	4
									FT165/C200	165	130	200	3,5	M10	4
3DxK160M2A ,2B,4,6	42	110	12	45	340	223	643	13	FT265/C300	265	230i6	300	4,0	M12	4
									FT215/C250	215	180i6	250	4,0	M12	4
3DxK160L2,4,6	42	110	12	45	340	223	643	13	FT265/C300	265	230j6	300	4,0	M12	4
									FT215/C250	215	180i6	250	4,0	M12	4

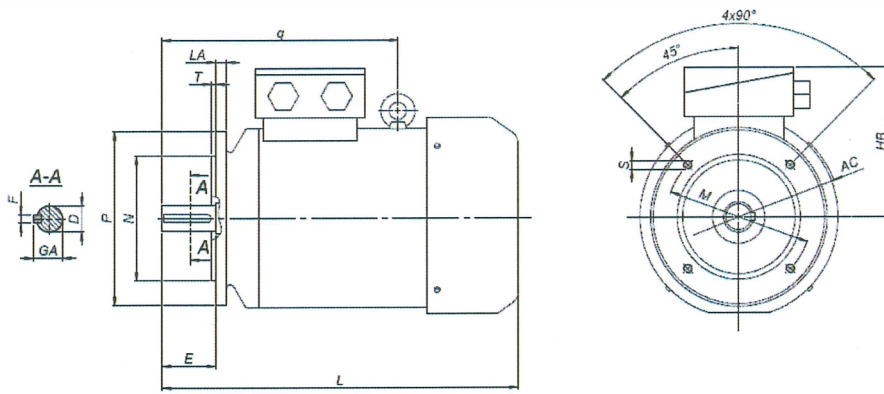

3DxK90-112



3DxK132-315

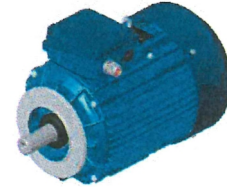

* silniki w fazie testów / prototypes made only

Wymiary silników kołnierzowych na łapach IM 834 (oprócz tarczy kołnierzowej) - patrz tabele dla IM 2001/835 na stronie 15
 Dimensions for foot-flange motors IM 834 (except flange shield) - see tables for IM 2001/835 on page 15

Producent zastrzega sobie prawo zmian wymiarów gabarytowych przedstawionych w katalogu.
 The manufacturer reserves the right to modify the overall dimensions of the products shown in this catalogue.

16. WIELKOŚĆ MECHANICZNA: 200÷315

FRAME SIZE: 200÷315

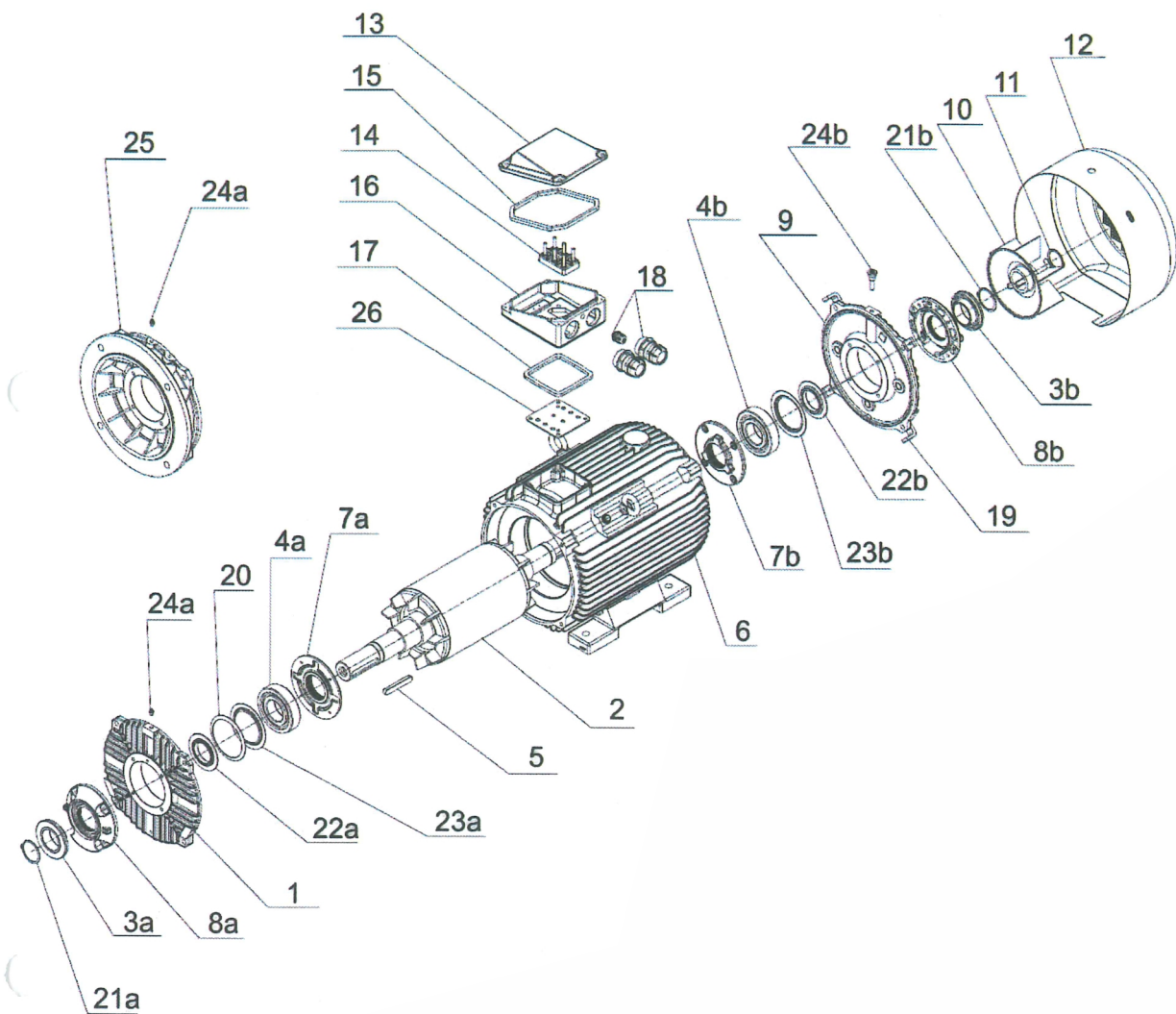

Pozycja Item	Opis Description
1	tarcza łożyskowa DE I <i>DE shield</i>
2	wirnik I <i>rotor</i>
3a,b	uszczelnienie wału I <i>shaft seal</i>
4a,b	łożysko I <i>bearing</i>
5	wpust I <i>key</i>
6	stojan z łapami I <i>housing with feet</i>
7a,b	pokrywa łożyskowa wewnętrzna I <i>internal bearing cap</i>
8a,b	pokrywa łożyskowa zewnętrzna I <i>external bearing cap</i>
9	tarcza łożyskowa NDE I <i>NDE shield</i>
10	przewietrznik I <i>fan</i>
11	Pierścień osadczy I <i>Seeger ring</i>
12	osłona przewietrznika I <i>fan cover</i>
13	pokrywa skrzynki I <i>terminal box cover</i>
14	tabliczka zaciskowa I <i>terminal board</i>
15	uszczelka pokrywy I <i>rubber gasket</i>
16	skrzynka zaciskowa I <i>terminal box</i>
17	uszczelka skrzynki I <i>rubber gasket</i>
18	dławnica I <i>glands</i>
19	mocownik osłony przewietrznika I <i>fan cover support</i>
20	podkładka falista I <i>spring washer</i>
21a,b	pierścień osadczy I <i>seeger ring</i>
22a,b	odrzutnik smaru I <i>grease shield</i>
23a,b	pierścień łożyskowy wewnętrzny I <i>bearing internal ring</i>
24a,b	smarownicza I <i>grease nipple</i>
25	tarcza kołnierzowa B5 I <i>flange B5</i>
26	uszczelka skrzynki I <i>rubber gasket</i>

DE - strona napędowa I *drive end*

NDE - strona przeciwnapędowa I *non drive end*

17. WIELKOŚĆ MECHANICZNA: 90÷180

FRAME SIZE: 90÷180

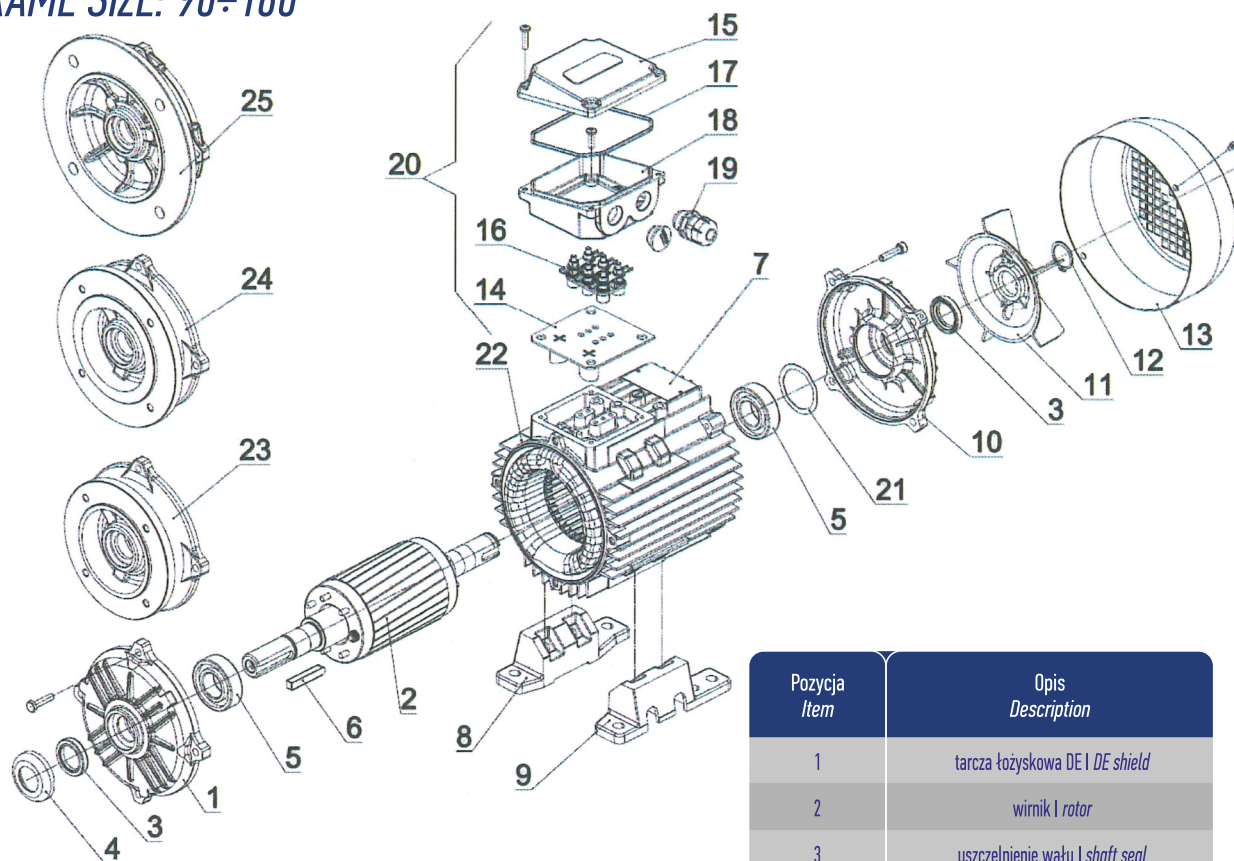

1 - tylko dla silników wielkości mechanicznej 90 - 132
only for frame size 90 - 132

DE - strona napędowa | drive end

NDE - strona przeciwnapędowa | non drive end

Pozycja Item	Opis Description
1	tarcza łożyskowa DE DE shield
2	wirnik rotor
3	uszczelnienie wału shaft seal
4	osłona uszczelnienia shaft seal cover
5	łożysko bearing
6	wpust key
7	tabliczka znamionowa name plate
8	łapa lewa sx food
9	łapa prawa dx food
10	tarcza łożyskowa NDE NDE shield
11	przewietrznik fan
12	pierścień osadczy seeger ring
13	osłona przewietrznika fan cover
14	uszczelka skrzynki rubber gasket
15	pokrywa skrzynki terminal box cover
16	tabliczka zaciskowa terminal board
17	uszczelka pokrywy rubber aasket
18	skrzynka zaciskowa terminal box
19	dławnica gland
20	skrz. zacisk. zestaw terminal box complete
21	podkładka falista spring washer
22	stojan stator
23(1)	tarcza kołnierзова B14/C2 flange B14/C2
24(1)	tarcza kołnierзова B14/C1 flange B14/C1
25	tarcza kołnierзова 85 flange 85



Detrans[®]

CRANES & COMPONENTS

jakość i nowoczesność tradycją od 1945 roku

Centrum Projektowo-Wdrożeniowe
DETRANS Sp. z o.o. Sp. k.

NIP : 6482772915
REGON : 360529569

KRS : 0000537512
e-mail: detrans@detrans.pl