

Detrans®

CRANES & COMPONENTS

jakość i nowoczesność tradycją od 1945 roku

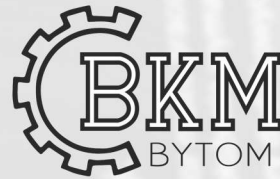

TRÓJFAZOWE SILNIKI INDUKCYJNE PIERŚCIENIOWE DŹWIGNICOWE

THREE - PHASE INDUCTION SLIP - RING CRANE MOTORS

WWW.DETRANS.PL

Spis treści

1. CHARAKTERYSTYKA WYKONANIA.....	2
<i>Features</i>	
2. WYKONANIE NA ŻYCZENIE.....	2
<i>Features on request</i>	
3. SPOSÓB ZAMAWIANIA.....	2
<i>How to order</i>	
4. PARAMETRY EKSPLOATACYJNE SILNIKÓW.....	3
<i>PERFORMANCES OF MOTORS</i>	
5. Wymiary montażowe silników na łapach.....	6
<i>Mounting dimensions for foot-mounted motors</i>	
6. Wymiary gabarytowe silników na łapach.....	6
<i>Overall dimensions for foot-mounted motors</i>	
7. Wymiary montażowe silników kołnierzowych.....	7
<i>Mounting dimensions for flange-mounted motors</i>	
8. Wymiary gabarytowe silników kołnierzowych.....	7
<i>Overall dimensions for flange-mounted motors</i>	
9. Wymiary montażowe silników kołnierzowych na łapach.....	8
<i>Mounting dimensions for foot-flange-mounted motors</i>	
10. Wymiary gabarytowe silników kołnierzowych na łapach.....	8
<i>Overall dimensions for foot-flange-mounted motors</i>	

1. CHARAKTERYSTYKA WYKONANIA

Features

- silniki przeznaczone są do pracy przerywanej
- S3-25%, S3-40%, S3-60%, S3-100%;
- napięcie znamionowe 400 [V];
- częstotliwość napięcia zasilania 50 [Hz];
- temperatura otoczenia od -15 do +40[°C];
- wysokość instalowania do 1000 [m] n.p.m.;
- izolacja klasy F;
- stopień ochrony IP 44;
- z jednym czopem końcowym wału wg rysunku wymiarowego;
- z termistorowym czujnikiem temperatury w czołach uzwojenia stojana;
- skrzynka zaciskowa z dławnicami i tabliczką 6- zaciskową i 3- zaciskową.
- *rated outputs for S3 - 25%, S3- 40%, S3 - 60%,*
- *S3 - 100% type of duty;*
- *rated voltage 400 [V];*
- *frequency 50 [Hz] ambient temperature from -15[0C] to +40[0C];*
- *altitude up to 1000 [m] above sea level;*
- *insulation class F;*
- *protection degree IP 44;*
- *with one free shaft extension according to dimension drawing;*
- *with temperature - sensitive resistors in the winding ends of the stator;*
- *terminal box with packing glands with 6 and 3 terminals.*

2. WYKONANIA NA ŻYCZENIA

Features on request

- z dwoma walcowymi czopami wału wg rysunku wymiarowego;
- na napięcia od 380V do 690 V (690 V tylko Y);
- na częstotliwości 60 Hz, przy czym zmieniają się parametry wirnika;
- przystosowane do pracy w klimacie tropikalnym TH, TA lub MT;
- o podwyższonym stopniu ochrony IP 55;
- fabryka wykonuje również silniki różniące się od wykonania podstawowego po uprzednim uzgodnieniu szczegółów konstrukcyjnych i terminów dostaw.
- *two cylindrical shaft extension according to dimension drawing;*
- *for rated voltage from 380 V to 690 V (690 V only Y);*
- *for 60 Hz frequency where the performances of the rotor are changed;*
- *fit for work in tropical climate TH, TA or MT;*
- *protection degree IP55;*
- *factory produces various types of motors but constructional details and delivery time must be agreed individually*

3. SPOSÓB ZAMAWIANIA

How to order

W zamówieniu należy podać pełne określenie typu silnika, moc, prędkość obrotową, napięcie zasilające, układ połączeń, częstotliwość formę wykonania oraz inne szczegóły niekatalogowego lub specjalnego wykonania,

In the order there must be clearly given: full designation of the motor, rated output, rated speed, rated voltage, phase connection, frequency, mounting form and all other details for non catalogue execution.

4. PARAMETRY EKSPLOATACYJNE SILNIKÓW

PERFORMANCES OF MOTORS

Typ silnika Type of motor	Rodzaj pracy Type of duty	P _n		n	η	cos θ _n	I ₁ przy 400 V Full-load amps at 400 V	m _{max}	M _n	Wirnik			k=U ₂ /3 · I ₂	J	Masa Weight
		Rated output	[HP]							I ₂	U ₂	Rf ₂₃			
		[kW]	[min ⁻¹]	[%]	[%]	[A]	[%]	[Nm]	[A]				[V]	[Ω]	[Ω]
2p=4 n _s =1500 obr/min; f=50 Hz ¾ największa dopuszczalna eksploatacyjna prędkość obrotowa 3000 obr/min															
2p=4 n _s =1500 rpm; f=50 Hz ¾ the maximum permissible rated speed of exploitation 3000 rpm															
Dxf 100 L-4A	S3-25%	1,3	1,8	1310	69,0	0,82	3,3	210	9,5	23,2			0,87		
	S3-40%	1,3	1,8	1310	69,0	0,82	3,3	210	9,5	23,2	35	0,046	0,87	0,009	40
	S3-60%	1,3	1,8	1310	69,0	0,82	3,3	210	9,5	23,2			0,87		
	S3-100%	1,1	1,5	1350	70,4	0,77	2,9	250	7,8	19,6			1,03		
Dxf 100 L-4B	S3-25%	1,7	2,3	1310	72,1	0,82	4,2	230	12,4	25,3			0,91		
	S3-40%	1,7	2,3	1310	72,1	0,82	4,2	230	12,4	25,3	40	0,052	0,91	0,010	45
	S3-60%	1,7	2,3	1310	72,1	0,82	4,2	230	12,4	25,3			0,91		
	S3-100%	1,5	2,0	1330	73,1	0,79	3,7	260	10,8	22,3			1,03		
Dxf 112 M-4A	S3-25%	3,3	4,5	1380	79,5	0,83	7,2	250	22,8	20,4			3,40		
	S3-40%	3,0	4,0	1390	80,6	0,82	6,6	280	20,6	18,0	120	0,195	3,85	0,020	65
	S3-60%	2,5	3,4	1410	81,2	0,78	5,7	340	16,9	14,4			4,81		
	S3-100%	2,2	3,0	1420	81,0	0,75	5,2	390	14,8	12,6			5,50		
Dxf 112 M-4B	S3-25%	4,4	5,9	1400	83,0	0,83	9,2	270	30,0	19,8			4,37		
	S3-40%	4,0	5,5	1410	83,4	0,81	8,6	300	27,1	17,6	150	0,205	4,92	0,025	70
	S3-60%	3,3	4,5	1430	83,7	0,77	7,4	370	22,0	14,2			6,10		
	S3-100%	3,0	4,0	1440	83,5	0,75	6,9	410	19,9	12,6			6,87		
Dxg 132 M-4A	S3-25%	7,0	9,5	1390	82,0	0,85	14,4	220	48,1	30,3			2,86		
	S3-40%	6,3	8,5	1400	83,0	0,84	13,0	250	42,9	26,6	150	0,123	3,26	0,035	90
	S3-60%	5,3	7,2	1420	83,8	0,81	11,3	300	35,6	21,9			3,95		
	S3-100%	4,8	6,5	1425	84,0	0,78	10,5	330	32,2	19,8			4,37		
Dxg 132 M-4B	S3-25%	8,3	11,3	1400	82,9	0,84	17,2	240	56,6	30,0			3,46		
	S3-40%	7,5	10,0	1410	83,8	0,83	15,6	270	50,8	26,5	180	0,138	3,92	0,040	95
	S3-60%	6,3	8,5	1425	84,7	0,80	13,4	320	42,2	22,0			4,72		
	S3-100%	5,5	7,5	1435	84,5	0,77	12,2	370	36,6	19,0			5,47		
Dxg 160 M-4	S3-25%	11,0	15,0	1410	84,2	0,84	22,4	250	74,5	41,5			2,43		
	S3-40%	10,0	13,4	1420	84,5	0,83	20,6	280	67,2	37,2	175	0,087	2,72	0,077	130
	S3-60%	8,5	11,5	1430	85,5	0,80	18,0	330	56,8	30,9			3,27		
	S3-100%	7,5	10,0	1440	85,6	0,77	16,4	380	49,7	27,3			3,70		
Dxg 160 L-4	S3-25%	16,5	22,2	1420	85,5	0,85	32,8	230	111,0	45,2			3,06		
	S3-40%	14,5	19,5	1430	87,0	0,84	28,6	270	96,8	39,0	240	0,103	3,55	0,098	155
	S3-60%	12,5	16,9	1440	87,5	0,82	25,2	310	82,9	33,8			4,10		
	S3-100%	11,0	15,0	1450	87,6	0,80	22,6	360	72,4	28,9			4,80		

Typ silnika Type of motor	Rodzaj pracy Type of duty	P _s		n	η	cos θ ₁	I ₁ przy 400 V	m _{max}	M ₁	Wimik			k=U ₂ /3·I ₂	J	Masa
		Rated output								Rated speed	Efficiency	Power factor			
		[kW]	[HP]	[min ⁻¹]	[%]	[%]	[A]	[%]	[Nm]				[A]	[V]	[Ω]
Dxg 180 L-4	S3-25%	22,0	30,0	1420	85,0	0,89	42,0	240	147,9	56,7	255	0,073	2,60	0,191	205
	S3-40%	19,5	26,3	1430	86,0	0,88	37,1	270	130,2	49,3			2,99		
	S3-60%	17,0	23,0	1440	86,5	0,86	33,0	310	112,7	42,5			3,46		
	S3-100%	15,0	20,0	1445	87,3	0,84	29,5	350	99,1	37,6			3,91		

2p=6 n_s=1000 obr/min; f=50 Hz % największa dopuszczalna eksploatacyjna prędkość obrotowa 2000 obr/min

2p=6 n_s=1000 rpm; f=50 Hz % the maximum permissible rated speed of exploitation 2000 rpm

Dxf 100 L-6A	S3-25%	1,1	1,5	850	63,4	0,70	3,6	160	12,3	22,9	30	0,054	0,75	0,011	40
	S3-40%	1,1	1,5	850	63,4	0,70	3,6	160	12,3	22,9			0,75		
	S3-60%	0,9	1,2	890	66,5	0,65	3,0	210	9,6	18,7			0,93		
	S3-100%	0,8	1,1	905	66,9	0,61	2,9	240	8,4	16,7			1,04		
Dxf 100 L-6B	S3-25%	1,5	2,0	860	67,1	0,79	4,1	190	16,6	23,4	40	0,061	0,99	0,012	45
	S3-40%	1,5	2,0	860	67,1	0,79	4,1	190	16,6	23,4			0,99		
	S3-60%	1,3	1,8	885	69,3	0,75	3,6	230	14,0	20,3			1,14		
	S3-100%	1,1	1,5	905	70,2	0,68	3,3	280	11,6	17,2			1,34		
Dxf 112 M-6A	S3-25%	2,2	3,0	890	74,0	0,76	5,6	210	23,6	15,2	95	0,2	3,61	0,028	65
	S3-40%	2,0	2,7	910	75,0	0,73	5,2	240	21,0	13,5			4,06		
	S3-60%	1,7	2,3	925	75,5	0,69	4,7	290	17,5	11,3			4,85		
	S3-100%	1,5	2,0	93	75,5	0,65	4,4	330	15,4	9,7			5,65		
Dxf 112 M-6B	S3-25%	3,3	4,5	920	77,3	0,72	8,6	250	34,2	14,6	145	0,29	5,73	0,030	70
	S3-40%	3,0	4,0	930	77,8	0,69	8,1	280	30,8	13,0			6,44		
	S3-60%	2,5	3,4	940	78,0	0,64	7,2	340	25,4	10,8			7,75		
	S3-100%	2,2	3,0	950	77,2	0,60	6,8	390	22,1	9,4			8,90		
Dxg 132 M-6A	S3-25%	5,0	6,8	915	79,0	0,78	11,7	190	52,2	27,0	120	0,119	2,57	0,045	90
	S3-40%	4,5	6,1	925	80,5	0,77	10,5	220	46,6	23,8			2,91		
	S3-60%	3,9	5,3	935	81,5	0,73	9,4	260	39,8	20,2			3,43		
	S3-100%	3,5	4,7	940	81,7	0,70	8,8	290	35,5	18,1			3,89		
Dxg 132 M-6B	S3-25%	6,1	8,3	935	80,2	0,75	14,6	210	62,3	25,3	145	0,132	3,31	0,051	95
	S3-40%	5,5	7,5	940	81,0	0,73	13,4	230	55,6	22,5			3,72		
	S3-60%	4,6	6,2	950	81,6	0,68	12,0	280	46,2	18,8			4,45		
	S3-100%	4,2	5,7	955	81,6	0,66	11,2	300	42,0	17,2			4,87		
Dxg 160 M-6	S3-25%	8,0	10,8	930	82,5	0,74	18,9	200	82,1	28,6	180	0,150	3,63	0,079	130
	S3-40%	7,0	9,5	940	83,1	0,71	17,1	230	71,1	24,6			4,22		
	S3-60%	6,0	8,1	950	83,5	0,67	15,5	270	60,3	20,8			5,00		
	S3-100%	5,5	7,5	955	83,7	0,65	14,5	300	55,0	19,1			5,44		
Dxg 160 L-6	S3-25%	11,5	15,5	930	84,3	0,77	25,6	210	118,1	31,5	250	0,180	4,58	0,105	155
	S3-40%	10,0	13,4	940	85,2	0,76	22,3	240	101,8	26,5			5,45		
	S3-60%	8,5	11,5	950	86,0	0,73	19,6	280	85,4	22,1			6,53		
	S3-100%	7,5	10,0	955	86,4	0,69	18,1	320	75,0	19,2			7,52		

Typ silnika Type of motor	Rodzaj pracy Type of duty	P _n		n	η	cos θ ₁	I ₁ przy 400 V	m _{max}	M _n	Wirnik			k=U ₂ /3 · I ₂	J	Masa
		Rated output								Rated speed	Efficiency	Power factor			
		[kW]	[HP]	[min ⁻¹]	[%]	[%]	[A]	[%]	[Nm]				[A]	[V]	[Ω]
Dxg 180 L-6	S3-25%	16,5	22,2	950	85,7	0,84	33,1	220	165,9	47,0			2,76		
	S3-40%	14,5	19,5	955	86,2	0,81	29,9	250	145,0	40,0			3,21		
	S3-60%	12,5	16,9	960	86,5	0,79	26,4	290	124,3	34,8	225	0,286	3,73	0,237	205
	S3-100%	11,0	15,0	965	86,3	0,75	24,5	320	108,9	30,3			4,29		
2p=8 n _s =750 obr/min; f=50 Hz % największa dopuszczalna eksploatacyjna prędkość obrotowa 1500 obr/min															
2p=8 n _s =750 rpm; f=50 Hz % the maximum permissible rated speed of exploitation 1500 rpm															
Dxg 132 M-8A	S3-25%	3,3	4,5	670	72,0	0,73	9,0	200	47,0	15,0			5,20		
	S3-40%	3,0	4,0	680	73,5	0,71	8,3	220	42,1	13,5			5,77		
	S3-60%	2,5	3,4	695	74,5	0,66	7,3	270	34,3	11,0	135	0,328	7,08	0,053	90
	S3-100%	2,2	3,0	705	74,0	0,61	7,0	310	29,8	9,8			7,95		
Dxg 132 M-8B	S3-25%	4,5	6,1	675	74,0	0,71	12,4	190	63,7	15,3			6,6		
	S3-40%	4,0	5,5	685	75,2	0,68	11,3	220	55,8	13,5			7,48		
	S3-60%	3,5	4,7	695	75,9	0,64	10,4	250	48,1	11,5	175	0,205	8,78	0,066	95
	S3-100%	3,0	4,0	705	75,8	0,59	9,7	300	40,6	9,6			10,52		
Dxg 160 M-8	S3-25%	6,2	8,4	675	77,1	0,76	15,3	190	87,7	25,7			3,59		
	S3-40%	5,5	7,5	685	78,6	0,74	13,7	220	76,7	21,8			4,24		
	S3-60%	4,7	6,3	695	80,2	0,71	11,9	260	64,6	18,1	160	0,233	5,10	0,098	130
	S3-100%	4,0	5,5	705	81,0	0,66	10,8	310	54,2	14,8			6,24		
Dxg 160 L-8	S3-25%	8,0	10,8	680	78,5	0,76	19,4	190	112,3	24,7			4,79		
	S3-40%	7,0	9,5	690	80,0	0,72	17,6	220	96,9	21,0			5,64		
	S3-60%	6,0	8,1	700	81,0	0,69	15,5	260	81,8	17,4	205	0,123	6,80	0,119	150
	S3-100%	5,2	7,0	705	81,1	0,64	14,4	300	70,4	14,7			8,05		
Dxg 180 L-8	S3-25%	11,5	15,5	705	85,0	0,75	26,0	190	155,8	34,9			3,55		
	S3-40%	10,0	13,4	715	85,6	0,72	23,4	220	133,6	30,0			4,14		
	S3-60%	8,5	11,5	720	86,2	0,69	20,6	260	112,7	25,5	215	3	4,87	0,235	205
	S3-100%	7,5	10,0	725	86,2	0,65	19,3	300	98,8	22,3			5,57		

k – wartość rezystancji, którą należy włączyć w obwód każdej fazy wirnika aby przy zatrzymaniu wirnika (0 obr/min) uzyskać moment rozruchowy równy momentowi maksymalnemu silnika (M_{max}).

k – resistance value which must be switched on the circuit of each phase of the rotor in order to attain, starting torque equal to the break-down torque (M_{max}), during stopping the rotor (0 rpm).

5. WYMIARY MONTAŻOWE SILNIKÓW NA ŁAPACH

MOUNTING DIMENSIONS FOR FOOT-MOUNTED MOTORS

Typ Type	A	B	C	D, DA	E, EA	F, FA	GA, GC	H	K
	mm	mm	mm	mm	mm	mm	mm	mm	mm
Dxf 100L ...	160	140	63	28j6	60	8h9	31,0	100	12
Dxf 112M ...	190	140	70	28j6	60	8h9	31,0	112	12
Dxg 132M ...	216	178	89	38k6	80	10h9	41,0	132	12
Dxg 160M ...	254	210	108	42k6	110	12h9	45,0	160	15
Dxg 160L ...	254	254	108	42k6	110	12h9	45,0	160	15
Dxg 180L ...	279	279	121	48k6	110	14h9	51,5	180	15

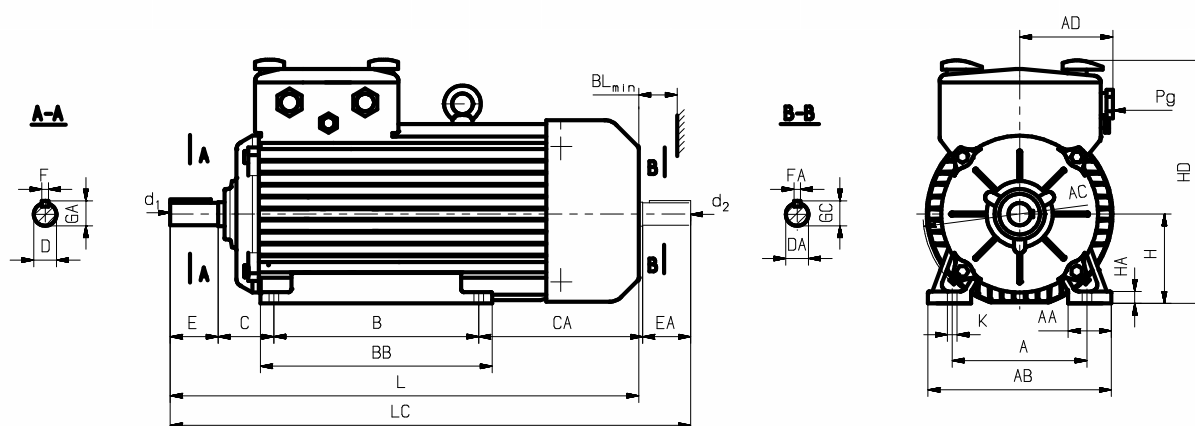

6. WYMIARY GABARYTOWE SILNIKÓW NA ŁAPACH

OVERALL DIMENSIONS FOR FOOT-MOUNTED MOTORS

Typ Type	AA	AB	AC	AD	BB	BL	CA	d1, d2	HA	HD	L	L	P _s		Łożysko nr Bearing No
	mm	mm	mm	mm	mm	mm	mm	mm	mm	mm	mm	mm	dla klimatu umiarkowanego for moderate climate	dla klimatu morskiego for marine climate	
Dxf 100L ...	45	205	206	132	240	20	287	M10	15	277	545	610	3 x M25 x 1,5	3 x M20 x 1	6306 2Z
Dxf 112M ...	54	235	245	155	280	20	300	M10	17	307	565	630	2 x M32 x 1,5 1 x M25 x 1,5	2 x M27 x 1,5 1 x M20 x 1	6306 2Z
Dxg 132M ...	56	260	274	155	280	40	329	M12	19	338	640	756	2 x M32 x 1,5 1 x M25 x 1,5	2 x M27 x 1,5 1 x M20 x 1	6308 2Z
Dxg 160M ...	60	310	323	180	310	40	329	M16	23	385	749	867	2 x M40 x 1,5 1 x M25 x 1,5	2 x M33 x 1,5 1 x M20 x 1	6309 2Z
Dxg 160L ...	60	310	323	180	370	40	344	M16	23	385	808	926	2 x M40 x 1,5 1 x M25 x 1,5	2 x M33 x 1,5 1 x M20 x 1	6309 2Z
Dxg 180L ...	70	345	360	180	400	40	370	M16	26	430	870	990	2 x M40 x 1,5 1 x M25 x 1,5	2 x M33 x 1,5 1 x M20 x 1	6311 2Z

Formy wykonania:

- IM 1001, IM 1011, IM 1031, IM 1051, IM 1061, IM 1071 - wg IEC 34-7, PN-EN 60034-7
- IM B3, IM B6, IM B7, IM B8, IM V5, IM V6 - wg IEC 34-7, PN-EN 60034-7

Mounting forms:

- IM 1001, IM 1011, IM 1031, IM 1051, IM 1061, IM 1071 - per IEC 34-7, PN-EN 60034-7
- IM B3, IM B6, IM B7, IM B8, IM V5, IM V6 - per IEC 34-7, PN-EN 60034-7

7. WYMIARY MONTAŻOWE SILNIKÓW KOŁNIERZOWYCH

MOUNTING DIMENSIONS FOR FLANGE-MOUNTED MOTORS

Typ Type	D,DA mm	E,EA mm	F,FA mm	GA,GC mm	M mm	N mm	P mm	S mm	T mm
DxKf 100L...	28j6	60	8h9	31,0	215	180j6	250	15	4
DxKf 112M...	28j6	60	8h9	31,0	215	180j6	250	15	4
DxKg 132M...	38k6	80	10h9	41,0	265	230j6	300	15	4
DxKg 160M...	42k6	110	12h9	45,0	300	250j6	350	19	5
DxKg 160L...	42k6	110	12h9	45,0	300	250j6	350	19	5
DxKg 180L...	48k6	110	14h9	51,5	300	250j6	350	19	5

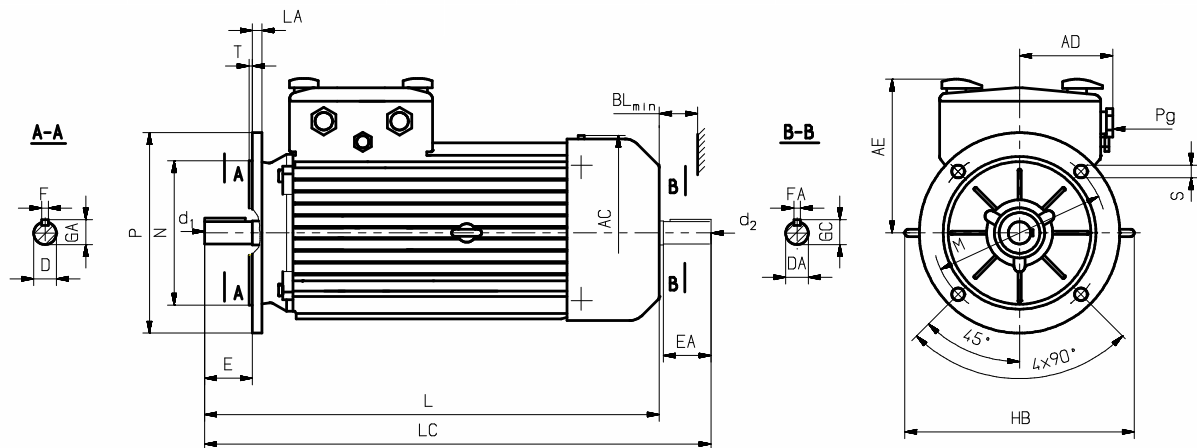

8. WYMIARY GABARYTOWE SILNIKÓW KOŁNIERZOWYCH

OVERALL DIMENSIONS FOR FLANGE-MOUNTED MOTORS

Typ Type	AA mm	AE mm	BL mm	HB mm	d1,d2 mm	L mm	LA mm	LC mm	P _g		Łożyisko nr Bearing No
									dla klimatu umiarkowanego for moderate climate	dla klimatu morskiego for marine climate	
DxKf 100L...	206	177	20	275	M10	545	11	610	3 x M25 x 1,5	3 x M20 x 1	6306 2Z
DxKf 112M...	245	195	20	325	M10	565	12	630	2 x M32 x 1,5 1 x M25 x 1,5	2 x M27 x 1,5 1 x M20 x 1	6306 2Z
DxKg 132M...	274	205	40	360	M12	640	12	756	2 x M32 x 1,5 1 x M25 x 1,5	2 x M27 x 1,5 1 x M20 x 1	6308 2Z
DxKg 160M...	323	225	40	415	M16	749	13	867	2 x M40 x 1,5 1 x M25 x 1,5	2 x M33 x 1,5 1 x M20 x 1	6309 2Z
DxKg 160L...	323	225	40	415	M16	808	13	926	2 x M40 x 1,5 1 x M25 x 1,5	2 x M33 x 1,5 1 x M20 x 1	6309 2Z
DxKg 180L...	360	250	40	485	M16	870	13	990	2 x M40 x 1,5 1 x M25 x 1,5	2 x M33 x 1,5 1 x M20 x 1	6311 2Z

Formy wykonania:

- IM 3001, IM 3011, IM 3031 - wg IEC 34-7, PN-EN 60034-7
- IM B5, IM V1, IM V3 - wg IEC 34-7, PN-EN 60034-7

Mounting forms:

- IM 3001, IM 3011, IM 3031 - per IEC 34-7, PN-EN 60034-7
- IM B5, IM V1, IM V3 - per IEC 34-7, PN-EN 60034-7

9. WYMIARY MONTAŻOWE SILNIKÓW NA ŁAPACH

MOUNTING DIMENSIONS FOR FOOT-MOUNTED MOTORS

Typ Type	A	B	C	D, DA	E, EA	F, FA	GA, GC	H	K	M	N	P	S	T
	mm	mm	mm	mm	mm	mm	mm	mm	mm	mm	mm	mm	mm	mm
DxLf 100L...	160	140	63	28j6	60	8h9	31,0	100	12	215	180j6	250	15	4
DxLf 112M...	190	140	70	28j6	60	8h9	31,0	112	12	215	180j6	250	15	4
DxLg 132M...	216	178	89	38k6	80	10h9	41,0	132	12	265	230j6	300	15	4
DxLg 160M...	254	210	108	42k6	110	12h9	45,0	160	15	300	250j6	350	19	5
DxLg 160L...	254	254	108	42k6	110	12h9	45,0	160	15	300	250j6	350	19	5
DxLg 180L...	279	279	121	48k6	110	14h9	51,5	180	15	300	250j6	350	19	5

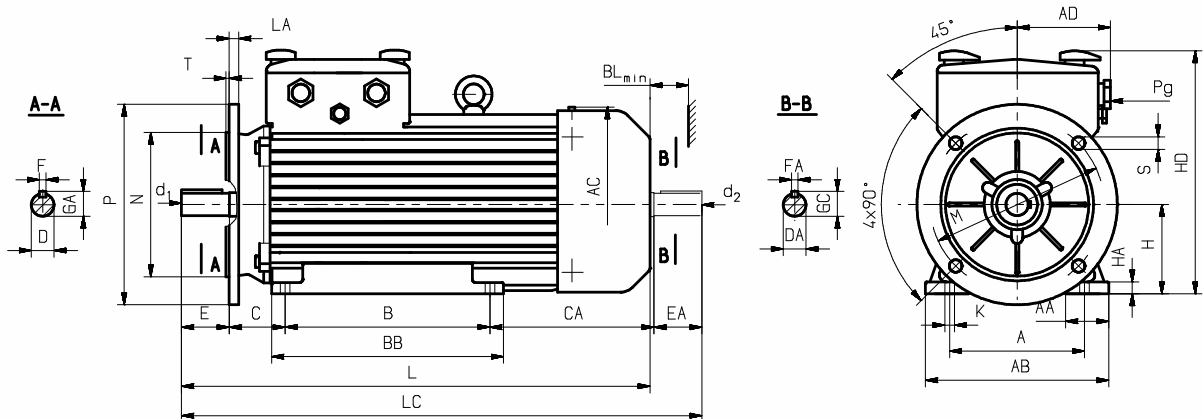

10. WYMIARY GABARYTOWE SILNIKÓW NA ŁAPACH

OVERALL DIMENSIONS FOR FOOT-FLANGE-MOUNTED MOTORS

Typ Type	AA	AB	AC	AD	BB	BL	CA	d1,d2	HA	HD	L	LA	LC	P _g dla klimatu umiarkowanego for moderate climate	dla klimatu morskiego for marine climate	Łożysko nr Bearing No
	mm	mm	mm	mm	mm	mm	mm	mm	mm	mm	mm	mm	mm			
DxLf 100L...	45	205	206	132	240	20	287	M10	15	277	545	11	610	3 x M25 x 1,5	3 x M20 x 1	6306 Z2
DxLf 112M...	54	235	245	155	280	20	300	M10	17	307	565	12	630	2 x M32 x 1,5 1 x M25 x 1,5	2 x M27 x 1,5 1 x M20 x 1	6306 Z2
DxLg 132M...	56	260	274	155	280	40	329	M12	19	338	640	12	756	2 x M32 x 1,5 1 x M25 x 1,5	2 x M27 x 1,5 1 x M20 x 1	6308 Z2
DxLg 160M...	60	310	323	180	310	40	329	M16	23	385	749	13	867	2 x M40 x 1,5 1 x M25 x 1,5	2 x M33 x 1,5 1 x M20 x 1	6309 Z2
DxLg 160L...	60	310	323	180	370	40	344	M16	23	385	808	13	926	2 x M40 x 1,5 1 x M25 x 1,5	2 x M33 x 1,5 1 x M20 x 1	6309 Z2
DxLg 180L...	70	345	360	180	400	40	370	M16	26	430	870	13	990	2 x M40 x 1,5 1 x M25 x 1,5	2 x M33 x 1,5 1 x M20 x 1	6311 Z2

Formy wykonania:

- IM 2001, IM 2011, IM 2031 - wg IEC 34-7, PN-EN 60034-7
- IMB35, IMV15, IMV36 - wg IEC 34-7, PN-EN 60034-7

Mounting forms:

- IM 2001, IM 2011, IM 2031 - per IEC 34-7, PN-EN 60034-7
- IMB35, IMV15, IMV36 - per IEC 34-7, PN-EN 60034-7



Detrans[®]

CRANES & COMPONENTS

jakość i nowoczesność tradycją od 1945 roku

Centrum Projektowo-Wdrożeniowe
DETRANS Sp. z o.o. Sp. k.

NIP : 6482772915
REGON : 360529569

KRS : 0000537512
e-mail: detrans@detrans.pl